



ES50LVS / ES90LVS MULTI-SPEED AIR HANDLER

Installation, Operation and Maintenance Manual



Ecosmartair
105 Haist Avenue, Unit 10
Vaughan, ON L4L 5V6
905-857-9755
ecosmartair.com



Contents

SAFETY INFORMATION	3
INTRODUCTION	4
MODES OF OPERATION	4
PERFORMANCE RATINGS	5
QUICK START-UP PROCEDURES	8
INSTALLATION	8
Clearances	8
Freeze Protection	9
Rear Piping Connections	9
Ecosmart Mounting	9
Plumbing	10
Pump	11
PIPING DIAGRAMS	12
Tankless Water Heater Piping	12
Combi-Boiler Piping	13
ELECTRICAL	14
Electrical Information	14
Electrical Connections Made to Quick Connects	14
Thermostat Wiring	15
Ecosmart Wiring Diagram	16
DIP SWITCH OPTIONS	18
Switch Locations	18
Heat CFM (ES50LVS)	19
Heat CFM (ES90LVS)	19
Cool CFM (ES50LVS)	19
Cool CFM (ES90LVS)	19
Options (ES50LVS and ES90LVS)	20
SEQUENCE OF OPERATION	20
Multi-stage Operation	20
Single-stage Operation	21
Cooling Mode (Multi and Single stage)	21

Dehumidification.....	22
Fan Mode	22
Constant Low Fan Circulation	22
Condenser Lockout/Freeze Protection	22
Pump Exerciser.....	23
SERVICE AND MAINTENANCE	23
Filter	23
Coils.....	23
Fan and Motor	23
TROUBLESHOOTING	24
Removing blower/control assembly	24
Thermostat call error	24
External pump does not run	24
External pump is noisy at start-up	24
Water heater temperature and pressure relief valve is weeping	24
Insufficient or no heat.....	25
Cold water at hot faucet	25
Fan runs for cooling but not for heating.....	25
Fan continues to run in cooling mode when thermostat is satisfied	25
Heating during standby mode	25
WARRANTY	25

All technical information subject to change without notice.

SAFETY INFORMATION

It is the responsibility of the installer to ensure the installation complies with all national and local building codes and standards, in addition to the instructions outlined in this manual. All applicable codes take precedence over any instructions made in this document.



This symbol indicates safety alerts. When you see this symbol on labels or in this manual, be alert to the potential for personal injury. Understand and pay particular attention to the signal words **DANGER**, **WARNING**, or **CAUTION**.

DANGER indicates an **imminently** hazardous situation, which if not avoided, **will result in death or serious injury.**

WARNING indicates a **potentially** hazardous situation, which if not avoided, **could result in death or serious injury.**

CAUTION indicates a **potentially** hazardous situation, which if not avoided, **may result in minor or moderate injury.** It is also used to alert against unsafe practices and hazards involving only property damage.



WARNING - Improper installation may create a condition where the operation of the product could cause personal injury or property damage. Only a qualified contractor, installer or service agency should install this product. Improper installation, adjustment, alteration, service or maintenance can cause injury or property damage. Refer to this manual for assistance.



CAUTION - This product must be installed in strict compliance with the installation instructions and any applicable local, state, and national codes including, but not limited to; building, electrical, and mechanical codes.



WARNING - FIRE OR ELECTRICAL HAZARD. Failure to follow the safety warnings exactly could result in serious injury, death, or property damage. A fire or electrical hazard may result causing property damage, personal injury or loss of life.



WARNING - Hot water from a boiler used to satisfy heating requirements can be heated to temperatures of 180°F. Parts containing water this hot can scald very quickly. Use extreme caution when servicing or performing maintenance on any parts containing hot water. To avoid severe burns, allow equipment to cool before performing maintenance.

INTRODUCTION

The **ecosmart Select** hydronic furnace is designed to maximize performance and comfort in residential or light commercial applications. The **ecosmart** can be used with a variety of heat sources such as boilers and water heaters and can be implemented in combo systems that provide domestic hot water as well as space heating. Smart control systems within the **ecosmart** allow extraction of maximum heat by allowing condensing high efficiency heat sources to work at their maximum efficiency while providing ultimate comfort with unmatched performance.

Simple, independent heat/cool and system parameters can easily be set by the installer to adjust for a wide variety of installations.

The **ecosmart** features a 5-speed high efficiency EC fan motor and a pump control which can operate a standard 120VAC pump or a variable speed pump from the 0-10V interface that provides LO/MED/HI functionality.

MODES OF OPERATION

- **MULTI STAGE** – fan runs through 3 speed stages with 5-minute intervals until the selected speed is reached, and the pump if a variable type is installed, runs through 3 speeds in unison with the fan stages. Note if a standard pump is used, the pump will run at a single speed only.
- **SINGLE STAGE** – fan runs at the selected speed and the pump runs at a single speed.

PERFORMANCE RATINGS

ES50LVS

Performance Data - Hot Water Capacities (BTUH) @ 70°F Entering Air Temperature										
Entering Water Temperature										
CFM	GPM	110°F	120°F	130°F	140°F	150°F	160°F	170°F	180°F	Water PD feet WC @140°F
300	3	10700	13400	16100	18810	21520	24240	26960	29680	2.32
	4	10970	13730	16500	19270	22050	24820	27600	30380	3.87
	5	11140	13940	16740	19550	22360	25180	27990	30810	5.77
400	3	13260	16610	19980	2350	26730	30110	33500	36890	2.32
	4	13730	17190	20670	24150	27640	31130	34620	38120	3.87
	5	14020	17550	21090	24640	28190	31740	35300	38860	5.77
600	3	17390	21820	26260	30720	35180	39660	44150	48640	2.32
	4	18330	22980	27640	32320	37000	41700	46400	51100	3.87
	5	18920	23710	28510	33320	38150	42970	47810	52650	5.77
700	3	19090	23950	28840	33740	38660	43590	48530	53470	2.32
	4	20270	25420	30590	35770	40970	46180	51390	56610	3.87
	5	21030	26360	31710	37070	42440	47820	53210	58610	5.77
800	3	20580	25840	31120	36420	41730	47070	52410	57760	2.32
	4	22020	27620	33250	38890	44550	50220	55900	61590	3.87
	5	22950	28770	34620	40480	46360	52250	58150	64050	5.77

ES90LVS

Performance Data - Hot Water Capacities (BTUH) @ 70°F Entering Air Temperature										
Entering Water Temperature										
CFM	GPM	110°F	120°F	130°F	140°F	150°F	160°F	170°F	180°F	Water PD feet WC @140°F
400	3	14200	17780	21370	24960	28560	32170	35780	39380	1.96
	4	14650	18350	22040	25740	29450	33160	36870	40580	3.26
	5	14930	18680	22440	26210	29980	33750	37520	41290	4.84
600	3	18930	23720	28530	33350	38180	43020	47860	52710	1.96
	4	19890	24920	29960	35010	40070	45140	50210	55280	3.26
	5	20500	25670	30850	36040	41240	46440	51650	56860	4.84
800	3	22630	28380	34150	39940	45750	51560	57380	63210	1.96
	4	24170	30300	36450	42610	48790	54970	61160	67360	3.26
	5	25160	31520	37910	44300	50710	57130	63550	69980	4.84
1,000	3	25580	32100	38640	45210	51790	58400	65000	71620	1.96
	4	27720	34770	41840	48930	56040	63160	70290	77430	3.26
	5	29120	36510	43910	51340	58780	66240	73700	81170	4.84
1,200	3	27970	35110	42280	49480	56710	63950	71200	78460	1.96
	4	30700	38520	46370	54240	62140	70050	77980	85910	3.26
	5	32520	40790	49080	57400	65730	74090	82450	90830	6.27

SPECIFICATIONS

PHYSICAL DATA - INCHES											
Model	Overall Dimensions W x D x H			Supply Opening W x D		Side Return				Piping Location	
	A	B	C	D	E	F	G	H	I	J	K
ES50LVS	14.0	21.0	29.0	11.8	17.8	18.3	14.3	1.4	2.0	2.8	2.4
ES90LVS	21.0	21.0	29.0	18.8	17.8	18.3	14.3	1.4	2.0	2.8	2.4

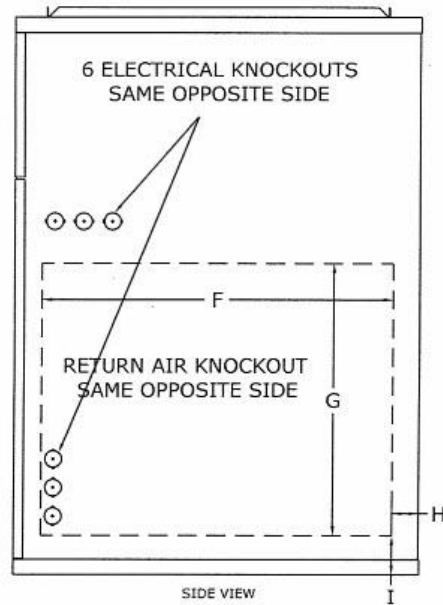
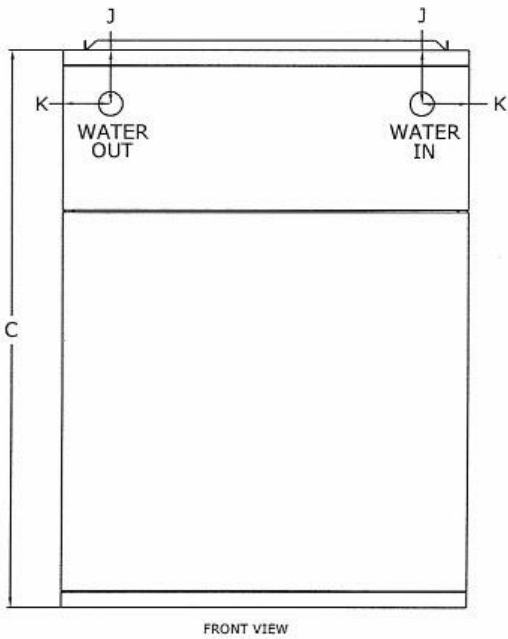
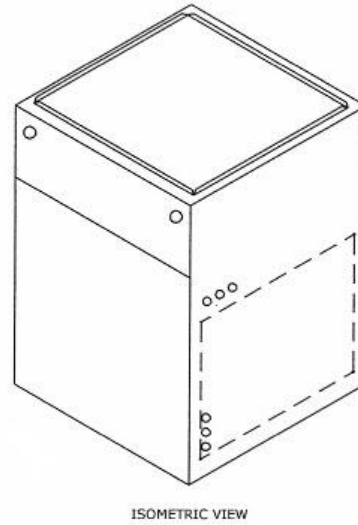
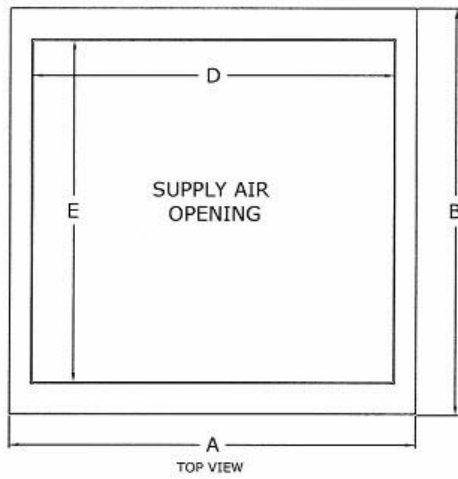

MODEL	ES50LVS	ES90LVS
DX Cooling Capacity (tons)	1 to 2	1.5 to 3.5
Power (Volts/Phase/Hz)	120/1/60	120/1/60
Cabinet Size W x D x H (in)	14 x 21 x 29	21 x 21 x 29
Supply Air Opening W x D (in)	11.8 X 17.8	18.8 x 17.8
Side Return Air Opening (in)	18.3 X 14.3	18.3 X 14.3
Recommended Filter Size (in)	16 x 20	16 x 20
Shipping Weight (lb)	85	95
Shipping Dimensions W x D x H (in)	15 x 24 x 30.5	22 x 24 x 30.5

ES50LVS ECM blower performance (CFM/amps)

SWITCH SETTING *	0.1" WC	0.2" WC	0.3" WC	0.4" WC	0.5" WC	0.6" WC	0.7" WC	0.8" WC	0.9" WC
300CFM	426 0.73	400 0.8	375 0.86	345 0.94	306 0.99	246 1.02	<200 1.10	<200 1.14	<200 1.19
400CFM	508 0.99	482 1.07	457 1.14	433 1.23	405 1.29	367 1.31	321 1.37	296 1.41	262 1.47
600CFM	670 1.86	664 1.92	640 2.01	624 2.08	609 2.17	564 2.14	547 2.22	525 2.34	502 2.41
700CFM	760 2.4	746 2.47	730 2.59	715 2.68	704 2.77	665 2.79	646 2.86	623 2.95	606 3.04
800CFM	857 3.19	840 3.26	825 3.37	819 3.44	803 3.53	772 3.59	750 3.62	743 3.73	719 3.80

ES90LVS ECM blower performance (CFM/amps)

SWITCH SETTING *	0.1" WC	0.2" WC	0.3" WC	0.4" WC	0.5" WC	0.6" WC	0.7" WC	0.8" WC	0.9" WC
400CFM	662 0.82	555 0.88	502 0.95	463 1.08	406 1.11	371 1.19	308 1.25	264 1.32	220 1.35
600CFM	779 1.23	730 1.32	636 1.41	650 1.49	613 1.58	595 1.65	555 1.73	495 1.83	429 1.91
800CFM	936 1.88	903 1.99	873 2.08	830 2.19	794 2.26	790 2.37	764 2.46	734 2.55	709 2.62
1000CFM	1119 2.84	1085 2.96	1053 3.07	1023 3.3	996 3.29	995 3.35	970 3.44	934 3.55	910 3.65
1200CFM	1312 4.28	1278 4.4	1257 4.55	1232 4.62	1220 4.7	1201 4.89	1185 5.07	1160 5.19	1145 5.29

* CFM @ 0.5" WC

QUICK START-UP PROCEDURES

Refer to the installation instructions before following the start-up procedures.

1. Fill the system with water. Do not start the system.
2. Purge all air from the system. Isolation and purge valves are strongly recommended.
3. Purge all air from the space heating loop by closing the isolation valve on the return leg of the loop and open the drain to purge air. Open the return leg isolation valve and then close the drain valve.
4. Start the hot water generating equipment per the manufacturer's recommendations. Set the design water temperature to deliver the necessary amount of BTUs to the air handler.
5. Once all air has been purged, turn on the power to the **ecosmart** and set the room thermostat to heat and set the temperature high enough to initiate a call for heat. This will energize the air handler and in turn the fan and pump.
6. Once the heat source is supplying hot water, check supply and return pipes for a temperature difference to make sure there is flow. There should be a noticeable difference in temperature between supply and return lines. Use caution when supply water temperature is above 125°F / 51°C.

INSTALLATION

The installer must comply with all local and national code requirements pertaining to the installation of this equipment.

Clearances

The **ecosmart** is approved for up-flow, down-flow, and horizontal configurations. Clearances do not change with orientation. This hydronic furnace is for indoor installation only.

	Clearance from Combustibles (in)	Recommended Service Clearance (in)
Top	0	0
Bottom	0	0
Front	0	24
Back	0	0
Sides	0	0

Freeze Protection

It is not recommended to install the **ecosmart** in an unheated space.

Should the **ecosmart** be installed in an area where the ambient temperature may fall below freezing, ethylene or propylene glycol should be added into the hydronic heating system to protect against damage, which would not be covered under warranty. Make sure the glycol is compatible with all system components and is permitted by local and national codes.

Rear Piping Connections

The heating coil may be reversed to allow rear piping:

- Remove upper door
- Disconnect supply air sensor from extension cable
- Slide out heating coil
- Re-mount supply air sensor and grommet to opposite end of heating coil
- Remove rear knock-outs
- Slide in heating coil
- Use plastic plugs (provided) to close up holes on upper door

Ecosmart Mounting

The **ecosmart** can be installed in up flow, down flow and left or right horizontal applications. Install the **ecosmart** with the door in place to make sure the cabinet remains square. Flip the unit for down flow applications so that the top of the unit is now the bottom. No modification is required for any configuration.

The **ecosmart** can be suspended from floor joists, rafters or concrete using rods, pipe, angle supports or straps. Units must be hung level to ensure quiet operation.



CAUTION - Use any of the existing screw holes in the cabinet when using straps. If the existing screw is too short for securing a mounting strap, a longer screw should be used provided care is taken not to damage any internal components. Product warranty does not cover any damage or claims resulting from damage from longer screws or from the unit being improperly suspended.

The cabinet is designed so that the return air can be located on either side of the cabinet, or from the bottom of the cabinet. Position a filter rack so that the filter is readily accessible. A filter and filter rack are not included. Sides are marked for a standard 16 x 20 in filter rack.



WARNING - Special care should be taken in the vicinity of the coil to avoid puncture. Screw into opening flange instead of top of cabinet when fastening the supply air duct.

Plumbing

Install a ½ in sediment faucet or ball valve for use as a drain/purge valve. The drain valve must be located downstream of the pump and check valve, and upstream of the isolation valve (if isolation valve is present). With this arrangement, any air trapped in the system can easily be flushed out following the instructions in the Start-up & Troubleshooting sections. Isolation valves are recommended, but not required. Installing isolation valves facilitates easy servicing.

When the space heating loop connections are made to the domestic water connections:

- The heating loop connections should be positioned horizontally in a vertical section of the domestic water line for both inlet and outlet. Refer to the piping schematic for details.
- Connect the heating loop to the domestic water connections as close to the water heater as possible

Avoid sections of pipe in the heating loop that can trap air where possible. It is usually impossible to install a system without having at least one part of the system or heating coil able to trap air. This will not be a problem if the connection to the domestic water lines is made properly, and purge valves and air eliminator devices are installed.

- Following the flushing procedures in the start-up section will ensure that there is no air in the system after initial set-up.

Follow recommendations supplied by the manufacturer of the heating source being used.

ecosmart includes a flow switch connection where a flow switch can be connected to allow for domestic water priority. Note: the correct type of flow switch is a normally open (NO) device.

The flow switch closes when domestic water is flowing

Check Valve

A check valve may be required for your system to meet local codes and to work effectively. A check valve:

- Protects against back-flow of water to avoid short circuiting around the water heater during domestic use
- Protects against thermal siphoning
- Is required in all potable water systems

A drain pan is recommended underneath the appliance for all installations.

Pump

A pump is not included inside the **ecosmart**. Whether you are using an external pump or an internal built-in pump, it should be sized for the system. Pumps supplied with the heat generating units can be used as the sole pump provided it meets the needs of the system. This is especially the case in retrofit applications where a much larger pump may have previously been used in the system.

- When set up in multi-stage mode, the pump will operate as a 3-speed pump if it is a variable 0-10V type. If the pump is a standard 120VAC type, it will operate at a single speed only.
- When set up in single-stage mode, the pump will operate as a single-speed pump.
- The **ecosmart** controller has a built-in pump timer that exercises the pump for 1 minute every 24 hours to prevent the possibility of 'sticking' due to sediment etc.

Water Heater or Boiler Setup

Follow the manufacturer's installation and start-up instructions of the water heater or boiler. Make sure the equipment is turned off during installation and service. Make certain the equipment has been refilled and all air is purged from the system before turning on the heater.



WARNING - When the system requires water temperatures higher than 125°F, a mixing valve shall be installed to reduce domestic hot water temperature to safeguard against scalding.

Combo Systems

The **ecosmart** is ideal for use in combo systems which provide space heating and domestic hot water from a single heat source. Any properly sized gas, propane or oil fired water heater or boiler will work in a combo system. Make sure any water heater being used is approved for combo applications.

PIPING DIAGRAMS

Tankless Water Heater Piping

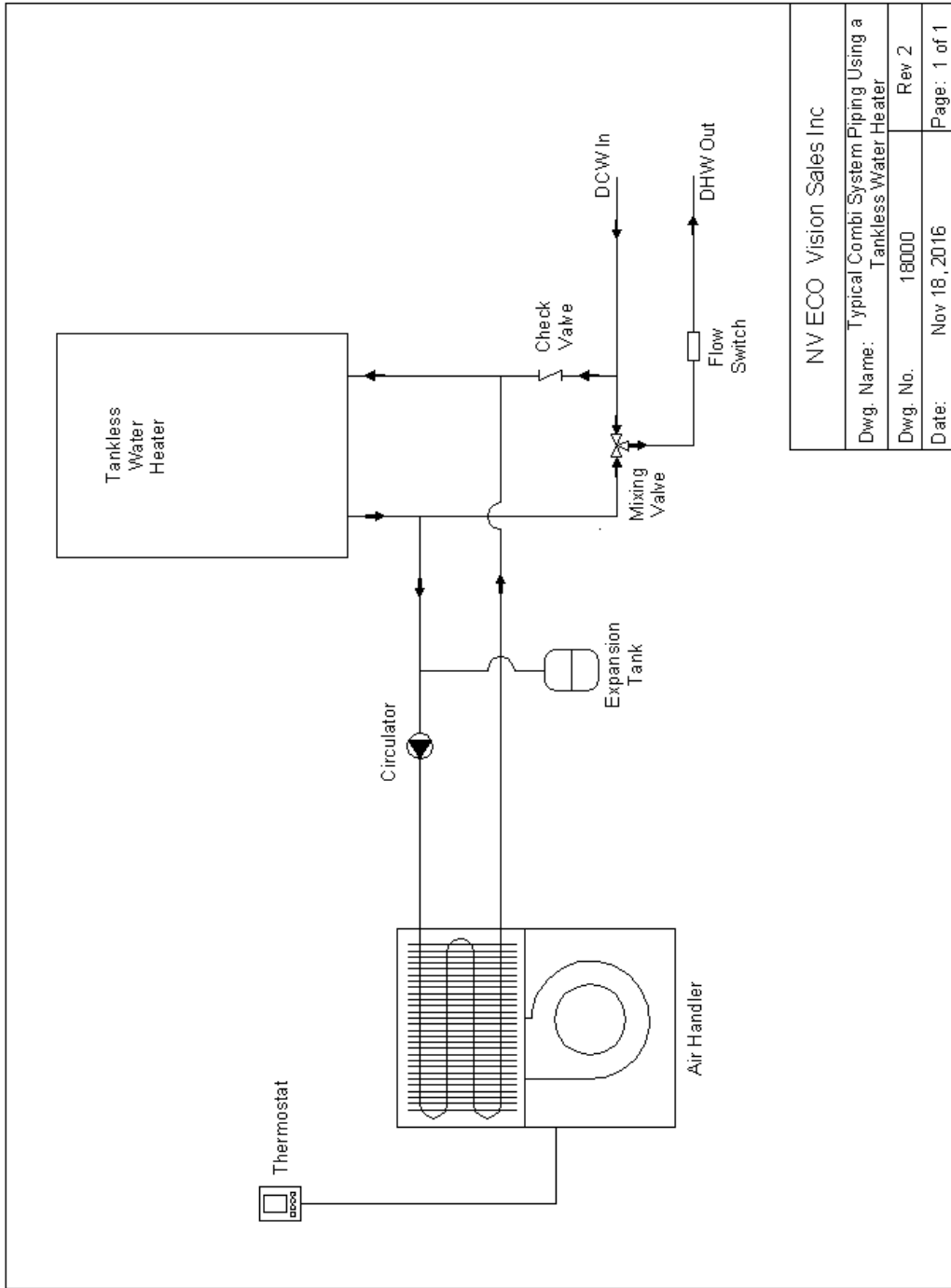

NVECO Vision Sales Inc	
Dwg. Name:	Typical Combi System Piping Using a Tankless Water Heater
Dwg. No.	18000 Rev 2
Date:	Nov 18, 2016 Page: 1 of 1

Combi-Boiler Piping

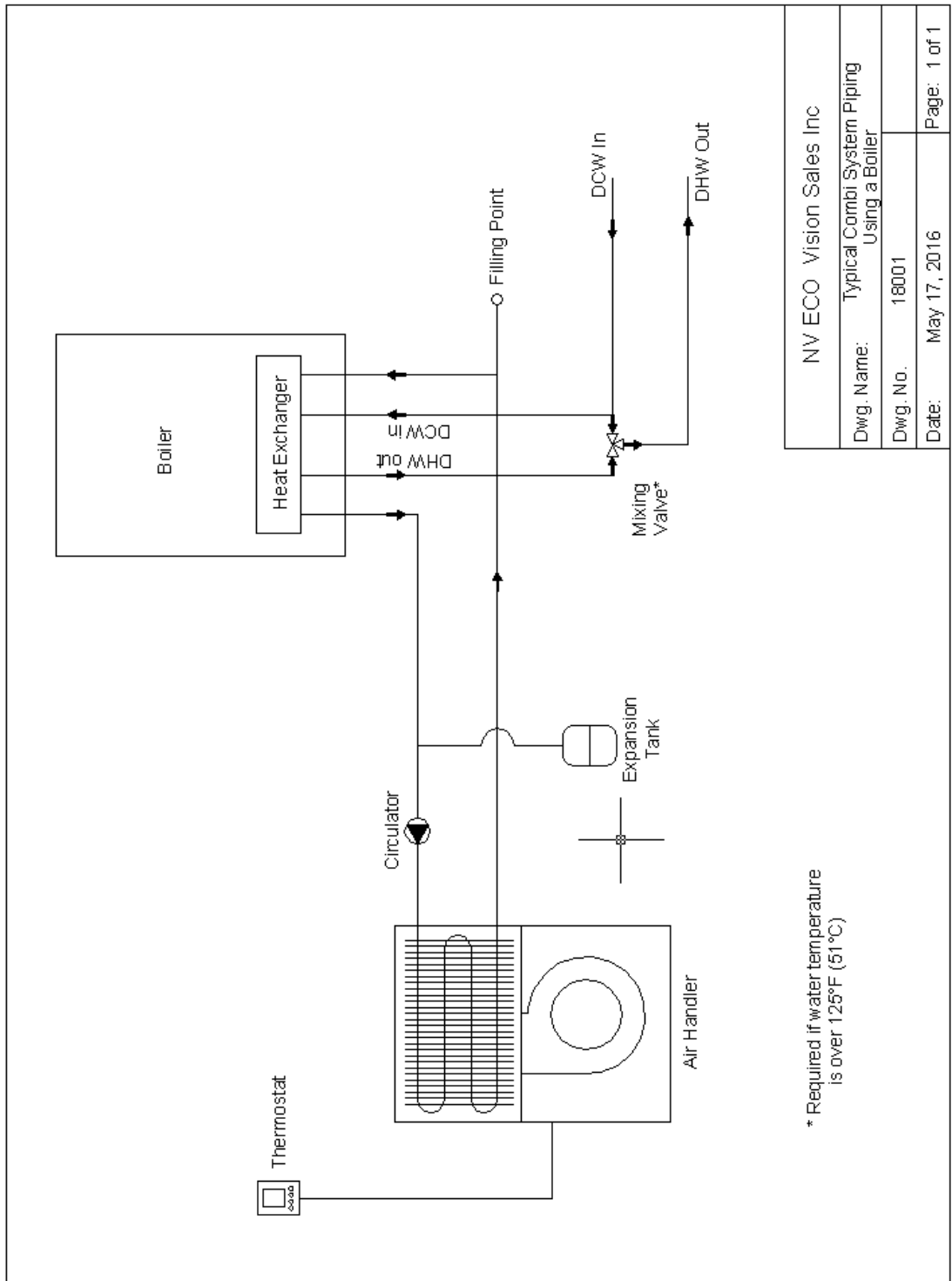

* Required if water temperature is over 125°F (51°C)

NV ECO Vision Sales Inc	
Dwg. Name:	Typical Combi System Piping Using a Boiler
Dwg. No.	18001
Date:	May 17, 2016
Page: 1 of 1	

ELECTRICAL



WARNING - Make sure the installation meets all national and local electrical codes.

Electrical Information

The ecosmart wiring diagram is located on the cover of the electrical box behind the lower front panel. Ratings data is located on the lower front panel.

- The ecosmart operates on 120VAC 60Hz single phase line voltage and should have its own dedicated breaker or fuse rated as per the MOP on the ratings label
- All control circuits are standard 24VAC
- **ecosmart** must be grounded via the green wire within the control box

Electrical Connections Made to Quick Connects

- Stranded or solid wire may be used
- Male tab size on control board: 0.250 in x 0.032 in
- Correct female disconnects to mate with male tabs:
 - Wire range: 22-18 AWG (Red) Panduit # DNF18-250 or equivalent
 - Wire range: 16-14 AWG (Blue) Panduit # DNF14-250 or equivalent



- Use a quality ratchet crimping tool to ensure reliable connections



Thermostat Wiring

Any standard heat/cool thermostat is compatible with the **ecosmart**.

Wire thermostat to lower right tabs as marked. The **ecosmart** supports optional 2-stage cooling if required.

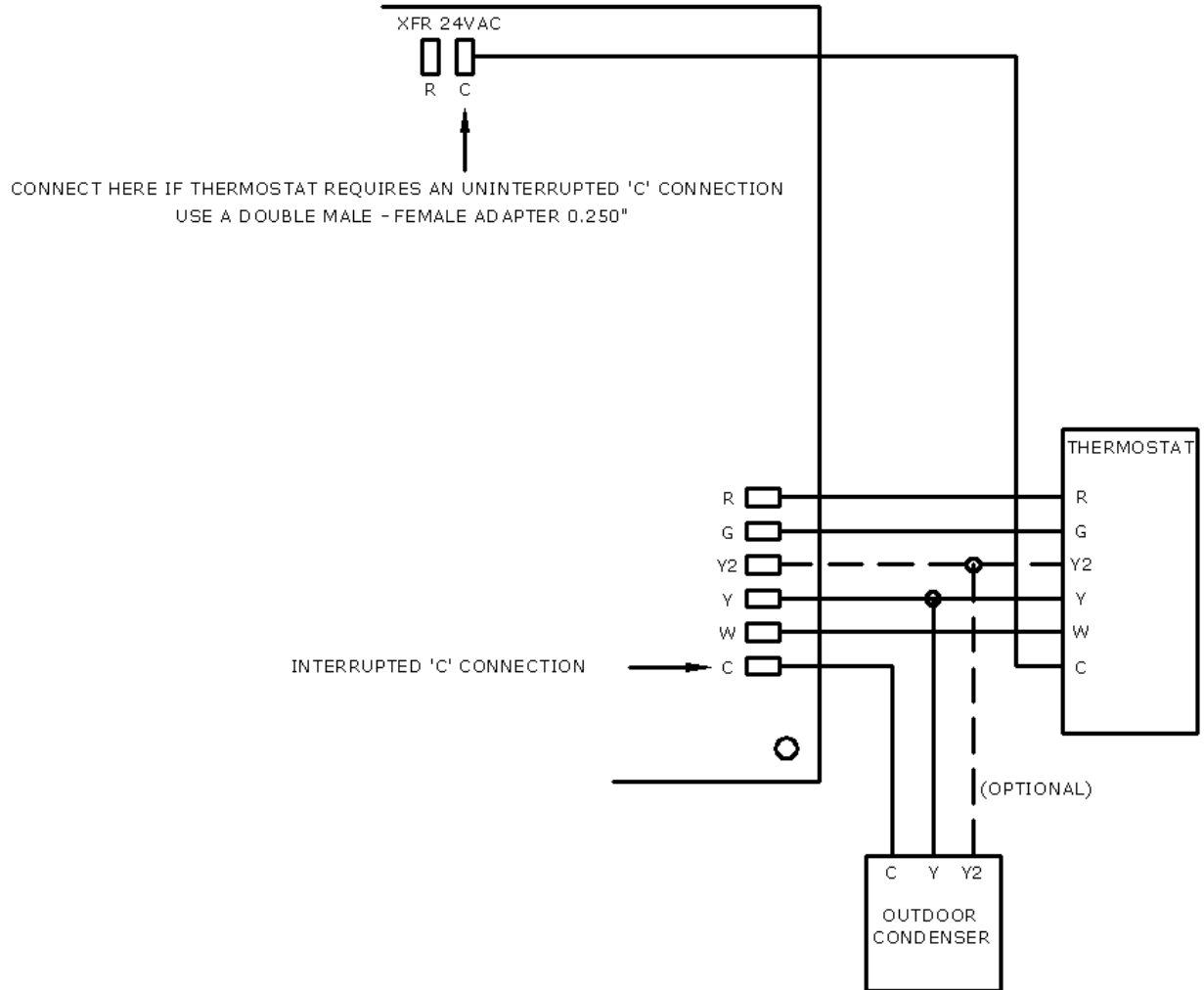

Ecosmart Wiring Diagram

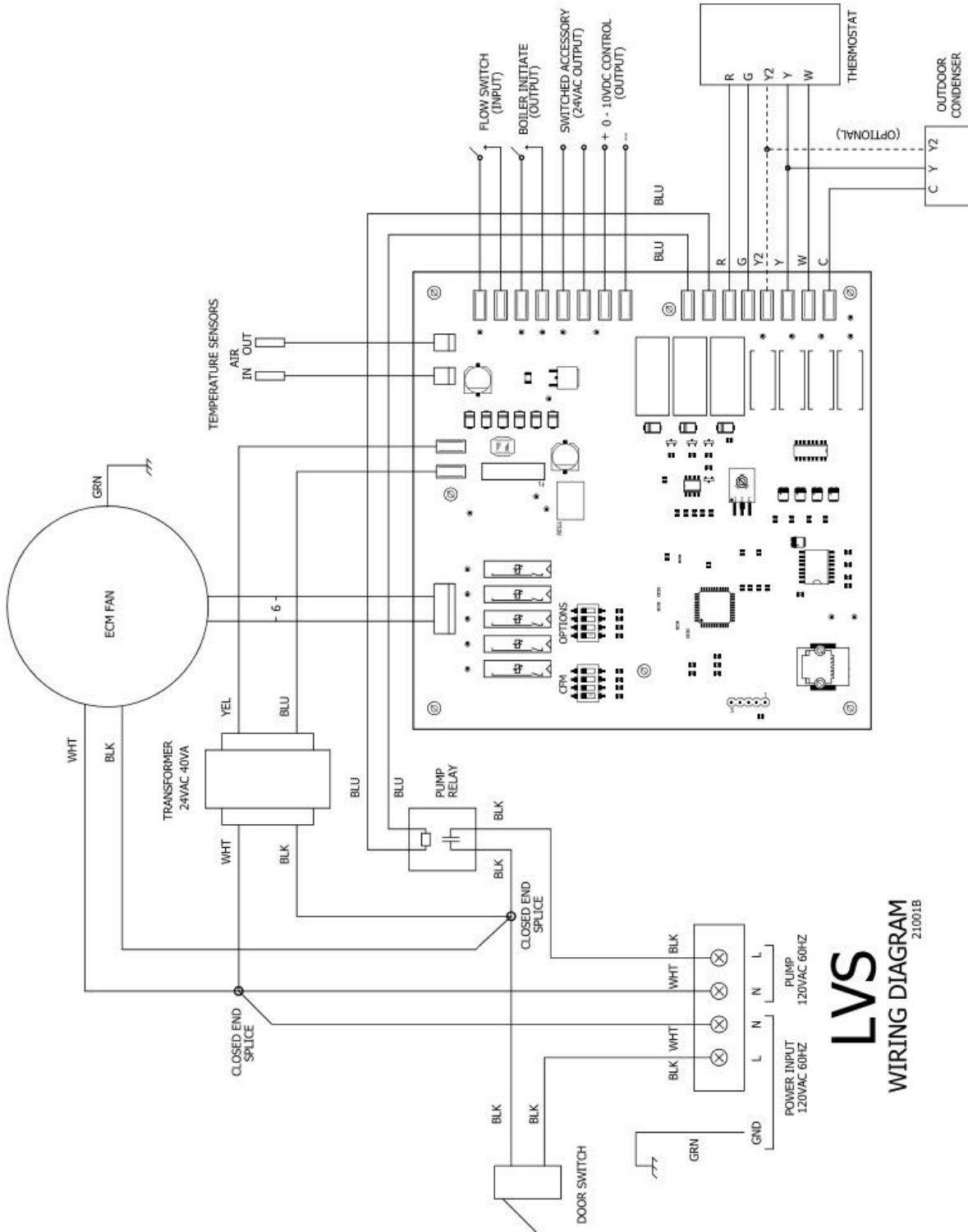

LVS
WIRING DIAGRAM
21001B

Miscellaneous wiring to the upper right tabs of control board as marked:

FLOW – When using a water heater and domestic water priority is required, connect a normally open (NO) flow switch. If there is a call for DHW, fan and pump will shut down after 1 minute. If flow switch is active longer than 30 minutes, fan and pump will resume normal operation.

-
- **BOILER** – dry contacts to initiate heat source
- **AUX 24V** – 24VAC output for humidifier or other accessory. Active when heating is on
- **0-10V** – 0 to 10VDC output to drive a variable speed pump (if installed). Variable speed pump will run at LO, MED or HI speeds in the multi-stage mode. Note if a standard AC pump is used, the pump will run at a single speed

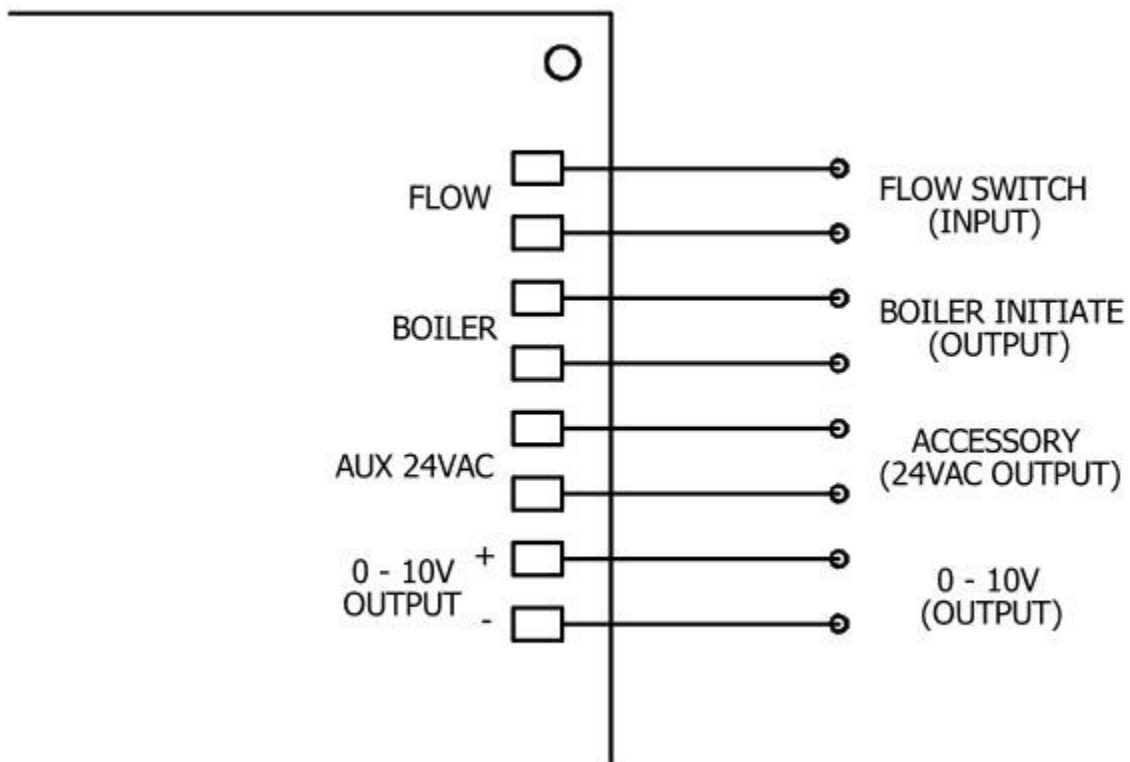

DIP SWITCH OPTIONS

Switch Locations

Two DIP switches labelled CFM and OPTIONS are located on the top left section of the control board. One switch is for Heat and Cool CFM rates, and the other for system options.

WARNING – to prevent damage, use a small screwdriver to change switch position.

Up is ON as marked on the switch body and each switch is identified with numbers below.

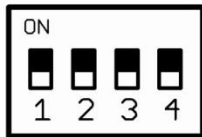

- **CFM** – switches 1 and 2 set Heat CFM rate
- **CFM** – switches 3 and 4 set Cool CFM rate
- **OPTIONS** – sets various system parameters

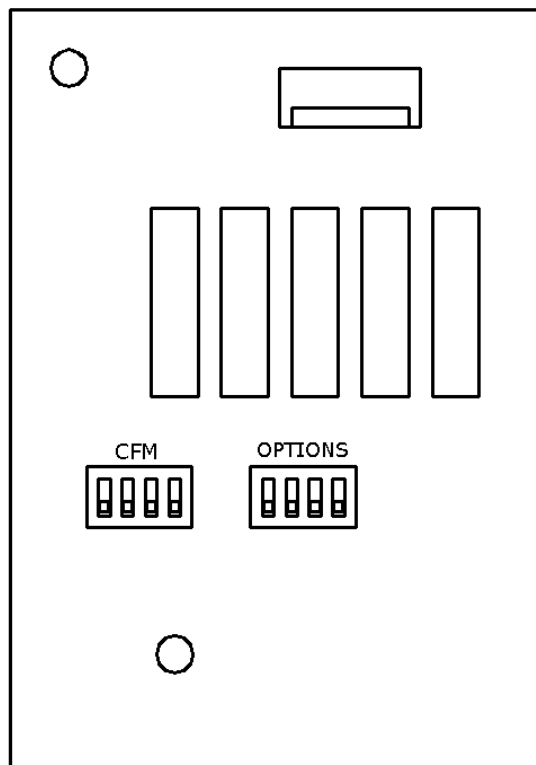

Heat CFM (ES50LVS)

MULTI-STAGE CFM @ 0.5" WC	SINGLE-STAGE CFM @ 0.5" WC	SWITCH 1	SWITCH 2	VAR. PUMP	STD. PUMP
300/300/400 (1)	400	OFF	OFF	LO/MED/HI (1)	HI
300/400/600 (1)	600	ON	OFF	LO/MED/HI (1)	HI
400/600/700 (1)	700	OFF	ON	LO/MED/HI (1)	HI
600/700/800 (1)	800	ON	ON	LO/MED/HI (1)	HI

(1) Multi-stage sequences are every 5 minutes until last speed is reached.

Heat CFM (ES90LVS)

MULTI-STAGE CFM @ 0.5" WC	SINGLE-STAGE CFM @ 0.5" WC	SWITCH 1	SWITCH 2	VAR. PUMP	STD. PUMP
400/400/600 (1)	600	OFF	OFF	LO/MED/HI (1)	HI
400/600/800 (1)	800	ON	OFF	LO/MED/HI (1)	HI
600/800/1000 (1)	1000	OFF	ON	LO/MED/HI (1)	HI
800/1000/1200 (1)	1200	ON	ON	LO/MED/HI (1)	HI

(1) Multi-stage sequences are every 5 minutes until last speed is reached.

Cool CFM (ES50LVS)

CFM @ 0.5" WC	SWITCH 3	SWITCH 4
400/400 (3)	OFF	OFF
400/600 (3)	ON	OFF
600/700 (3)	OFF	ON
700/800 (3)	ON	ON

Cool CFM (ES90LVS)

CFM @ 0.5" WC	SWITCH 3	SWITCH 4
600/600 (3)	OFF	OFF
600/800 (3)	ON	OFF
800/1000 (3)	OFF	ON
1000/1200 (3)	ON	ON

Options (ES50LVS and ES90LVS)

Mode	SWITCH 1	SWITCH 2	SWITCH 3	SWITCH 4
Constant circulating fan - runs at Heat CFM rate	OFF	X	X	X
Constant low circulating fan (2)	ON	X	X	X
Multi-stage	X	OFF	X	X
Single-stage	X	ON	X	X
Normal Fan Cooling - runs at higher Cool CFM rate	X	X	OFF	X
Dehumidification Fan Cooling (3)	X	X	ON	X
Test Mode off (4)	X	X	X	OFF
Test Mode on (4)	X	X	X	ON

(2) ES90LVS runs at 400 CFM, ES50LVS runs at 300 CFM.

(3) Fan Cooling runs at **lower** COOL CFM rate for 10 min. and then goes to **higher** rate.

(4) Test Mode – heat source is brought on, fan runs at Single Stage HEAT CFM setting and pump runs at full speed irrespective of thermostat setting. Useful for eliminating air in the system during installation.

SEQUENCE OF OPERATION

Multi-stage Operation

Thermostat calls for heat

- R is connected to W
- Heat generator is turned on
- Auxiliary 24VAC power is turned on
- Pump turns on 100%
- After a 15 second delay to allow for system water to heat up coil, fan ramps up as follows:
 1. **Stage 1 - Lower HEAT CFM fan speed for 5 minutes**
If a variable speed pump is installed, it runs at LO. If a standard single speed AC pump is installed it runs at HI.
 2. **Stage 2 - Medium HEAT CFM fan speed for 5 minutes**
If a variable speed pump is installed, it runs at MED. If a standard single speed AC pump is installed it runs at HI.
 3. **Stage 3 - High HEAT CFM fan speed until thermostat is satisfied**

If a variable speed pump is installed, it runs at HI. If a standard single speed AC pump is installed it runs at HI.

Thermostat is satisfied

- R is disconnected from W
 - Heat generator is turned off
 - Auxiliary 24VAC power is turned off
 - Pump turns off and fan speed ramps down to zero, extracting any remaining heat in the coil
-

Single-stage Operation

- R is connected to W
- Heat generator is turned on
- Auxiliary 24VAC power is turned on
- Pump turns on at 100%
- After a 15 second delay to allow for system water to heat up coil, fan ramps up to HEAT CFM speed
- If a variable speed pump is installed, it runs at HI. If a standard single speed AC pump is installed it runs at HI

Thermostat is satisfied

- R is disconnected from W
 - Heat generator is turned off
 - Auxiliary 24VAC power is turned off
 - Pump turns off and fan speed ramps down to zero, extracting any remaining heat in the coil
-

Cooling Mode (Multi and Single stage)

(Assumes a condenser and DX coil is installed within the system)

- R is connected to Y and Y2*
- Condenser turns on
- Fan ramps up to COOL CFM setting

* If thermostat and condenser support 2-stage cooling

Thermostat is satisfied

- Condenser turns off
- Fan speed ramps down to zero, extracting any remaining cooling from the DX coil

Dehumidification

When in cooling mode, a dehumidification function can be set using system switch 3 as follows:

- OFF - Normal cooling fan runs at rate set by COOL CFM switch
- ON - Fan Cooling runs at lower COOL CFM rate for 10 min. and then goes to higher rate

Fan Mode

- R is connected to G
- If fan is set to “ON” on thermostat, fan runs as follows:
 - If OPTION switch 1 is OFF, fan runs at selected HEAT CFM rate
 - If OPTION switch 1 is ON, fan runs at 300 CFM (ES50LVS), 400CFM (ES90LVS)
- If fan is set to “OFF” on thermostat, fan runs at HEAT or COOL CFM settings

Constant Low Fan Circulation

Fan may be run at a low rate using OPTION switch 1 as follows:

- OFF – fan runs at rate set by HEAT CFM switch
- ES50LVS runs at 300 CFM, ES90LVS runs at 400 CFM

Condenser Lockout/Freeze Protection

The **ecosmart** is equipped with a condenser lockout / freeze protection sensor to help prevent any damage to the hot water coil from a freeze up. In any mode, heating, cooling or standby, when the outlet air temperature sensor reads a temperature of 40°F or lower the **ecosmart** will bring on the circulating fan and energize the pump relay. If in cooling mode, the **ecosmart** will also turn off the condenser by breaking the C connection.

Pump Exerciser

- The circulating pump is exercised for 1 min every 24 hr when the **ecosmart** is OFF, COOLING (Y), COOLING2 (Y2) or FAN (G) to prevent the possibility of 'sticking' due to sediment and to meet local codes
- During the 1 min pump on-time, the fan is turned off and resumes once the pump exercising is completed
- Pump runs continuously if the outlet air temperature drops below 40°F to prevent the chance of freezing

SERVICE AND MAINTENANCE

NOTE: The **ecosmart** is not to be used for temporary heat during construction. Use for this purpose will void equipment warranty.

Filter

Inspect the filter monthly and replace, remove and vacuum or rinse as required. A clogged or inadequate filter may void product warranty. Replacement filter size is 16 x 20 x 1.

Coils

Air conditioning and heating coils should not require cleaning if the filter maintenance schedule is adhered to. If a filter is damaged or collapses from plugging, dust may foul the coils. If this happens, replace the filter and carefully vacuum the coils. The fan may need to be removed to gain access to the face of the heating coil.

Fan and Motor

Check fan for dust once a year. If dirty, vacuum or wash to remove dust. Keeping the fan blades clean will reduce noise and improve capacity and efficiency of the heating system.

TROUBLESHOOTING

Removing blower/control assembly

Blower and control assembly can be removed as a single piece:

- Turn off power to **ecosmart**
- Disconnect AIR OUT temperature sensor (white plug/socket) just above front centre plate
- Disconnect power, thermostat and other wiring from within control box
- Undo (Qty. 2) #1/4-20 bolts, lock washers and flat washers
- Slide out blower assembly

Thermostat call error

If the **ecosmart** does not run when the thermostat is calling, jumper R to W for heating or R to Y (Y2) to verify if the problem is with the thermostat or **ecosmart** control. Note that some thermostats have a delay (typically five minutes) before they will re-start cooling to prevent compressor damage.

External pump does not run

In areas where hard water is present the pump may stick and fail to run. Often, closing the isolation valve on the return leg and opening the drain port so that water flows through the pump can free this. If this fails to free the pump, removal for cleaning or replacement is necessary. The daily pump exerciser will help prevent pump sticking.

External pump is noisy at start-up

If sound has not diminished within 1 minute, air may be present in the system and may need re-purging. If the heat source is a water heater, check to make sure branch connections for the heating loop are horizontal to prevent the collecting of air in the loop.

Water heater temperature and pressure relief valve is weeping

A check valve or back-flow preventer may have been installed in the system. Some form of pressure relief may be required. Consult water heater manufacturer's instructions. Options are:

- Install expansion tank
- Install pressure relief valve; locate outlet over laundry tub or floor drain

Insufficient or no heat

- Check that the heat generator is functioning properly
- Plugged air filter or coil. Refer to maintenance section for filter care and coil cleaning
- Air in heating loop - purge system
- Inlet and outlet connections to **ecosmart** are backwards - reverse connections
- Water heater dip tube is restricted or damaged; check and/or replace
- Supply water temperature set too low or not calibrated properly - check water temperature
- Restrictions on heating loop - remove restrictions, check if valve is stuck, isolation valves could be too restrictive or left partially closed after purging, or a closed valve

Cold water at hot faucet

When the heat source is a water heater, the most probable cause is reverse flow through the heating loop from a stuck check valve - repair or replace valve.

Fan runs for cooling but not for heating

The room thermostat may be connected improperly. Refer to Electrical section or wiring schematic on **ecosmart** for proper installation.

Fan continues to run in cooling mode when thermostat is satisfied

The condenser shuts off but the **ecosmart** fan continues to run. This is often caused by older thermostats that have built-in heat anticipators. When cooling, the heat anticipator, in parallel with the thermostat contacts, allows a small current to flow to the **ecosmart** control board, keeping the fan on. The contactor in the condenser shuts off because it requires more current to stay on. Solution: replace with a modern thermostat which has no heat anticipator.

Heating during standby mode

Probable cause is thermal siphoning.

WARRANTY

Warranty is 3 years' parts. Visit ecosmartair.com for full details.