



ES50LVS / ES90LVS MULTI-SPEED AIR HANDLER

Installation, Operation and Maintenance Manual



Ecosmartair
105 Haist Avenue, Unit 10
Vaughan, ON L4L 5V6
905-857-9755
ecosmartair.com



P/N 14001G

Contents

SAFETY INFORMATION	4
INTRODUCTION	5
MODES OF OPERATION	5
PERFORMANCE RATINGS	6
SPECIFICATIONS	7
QUICK START-UP PROCEDURES	9
INSTALLATION	9
Clearances	9
Freeze Protection	10
Rear Piping Connections	10
Ecosmart Mounting	10
Plumbing	11
Check Valve	12
Drain Pan	12
Pump	12
Water Heater or Boiler Setup	12
Combo Systems	13
PIPING DIAGRAMS	14
Tankless Water Heater Piping	14
Combi-Boiler Piping	15
ELECTRICAL	16
Electrical Information	16
Electrical Connections Made to Quick Connects	16
LVS Main Wiring	17
LVS Main Wiring Information	18
LVS Wiring Diagram	19
LVS Miscellaneous Wiring	20
LVS Indicator Lights	20
DIP SWITCH OPTIONS	21
Switch Locations	21
Heat CFM (50LVS)	21

Heat CFM (90LVS)	22
Cool CFM (50LVS).....	22
Cool CFM (90LVS).....	22
Options (50LVS and 90LVS).....	22
SEQUENCE OF OPERATION	23
Multi-stage Operation.....	23
Single-stage Operation.....	24
Cooling Mode (Multi-stage and Single stage).....	24
Dehumidification.....	25
Fan Mode	25
Constant Low Fan Circulation	25
Condenser Lockout/Freeze Protection	25
Pump Exerciser.....	25
SERVICE AND MAINTENANCE	26
Filter	26
Coils.....	26
Fan and Motor	26
TROUBLESHOOTING	26
Thermostat call error	26
Water heater temperature and pressure relief valve is weeping	26
Cold water at hot faucet	26
Fan runs for cooling but not for heating.....	26
Fan continues to run in cooling mode when thermostat is satisfied	27
Fan not running.....	27
Smart WiFi thermostat not working properly.....	27
External pump does not run (sticking issue).....	28
External pump does not run (electrical issue)	28
External pump is noisy at start-up	29
Insufficient or no heat.....	29
Heating during standby mode	29
Pump and fan run continuously.....	29
REMOVING BLOWER/CONTROL ASSEMBLY	29
CONTROL ASSEMBLY LAYOUT	30

Final Assembly – Exploded View 32
Electrical Box– Exploded View 33
Blower & Heating Coil – Exploded View 34
Replacement Parts 35
WARRANTY36

All technical information subject to change without notice.

SAFETY INFORMATION

It is the responsibility of the installer to ensure the installation complies with all national and local building codes and standards, in addition to the instructions outlined in this manual. All applicable codes take precedence over any instructions made in this document.



This symbol indicates safety alerts. When you see this symbol on labels or in this manual, be alert to the potential for personal injury. Understand and pay particular attention to the signal words **DANGER**, **WARNING**, or **CAUTION**.

DANGER indicates an **imminently** hazardous situation, which if not avoided, **will result in death or serious injury.**

WARNING indicates a **potentially** hazardous situation, which if not avoided, **could result in death or serious injury.**

CAUTION indicates a **potentially** hazardous situation, which if not avoided, **may result in minor or moderate injury.** It is also used to alert against unsafe practices and hazards involving only property damage.



WARNING - Improper installation may create a condition where the operation of the product could cause personal injury or property damage. Only a qualified contractor, installer or service agency should install this product. Improper installation, adjustment, alteration, service or maintenance can cause injury or property damage. Refer to this manual for assistance.



CAUTION - This product must be installed in strict compliance with the installation instructions and any applicable local, state, and national codes including, but not limited to; building, electrical, and mechanical codes.



WARNING - FIRE OR ELECTRICAL HAZARD. Failure to follow the safety warnings exactly could result in serious injury, death, or property damage. A fire or electrical hazard may result causing property damage, personal injury or loss of life.



WARNING - Hot water from a boiler used to satisfy heating requirements can be heated to temperatures of 180°F. Parts containing water this hot can scald very quickly. Use extreme caution when servicing or performing maintenance on any parts containing hot water. To avoid severe burns, allow equipment to cool before performing maintenance.

INTRODUCTION

The **ecosmart** hydronic furnace is designed to maximize performance and comfort in residential or light commercial applications. The **ecosmart** can be used with a variety of heat sources such as boilers and water heaters and can be implemented in combo systems that provide domestic hot water as well as space heating. Smart control systems within the **ecosmart** allow extraction of maximum heat by allowing condensing high efficiency heat sources to work at their maximum efficiency while providing ultimate comfort with unmatched performance.

The **ecosmart** LVS features:

- Simple, independent heat/cool and system parameters can easily be set by the installer to adjust for a wide variety of installations.
- A 5-speed high efficiency EC fan motor and a pump control which can operate a standard 120VAC pump or a variable speed pump from the 0-10V interface that provides LO/MED/HI functionality.

MODES OF OPERATION

- **MULTI-STAGE** – fan runs through 3 speed stages with 5-minute intervals until the selected speed is reached, and the pump if a variable type is installed, runs through 3 speeds in unison with the fan stages. Note if a standard pump is used, the pump will run at a single speed only.
- **SINGLE-STAGE** – fan runs at the selected speed and the pump runs at a single speed.

PERFORMANCE RATINGS

50LVS

Performance Data - Hot Water Capacities (BTUH) @ 70°F Entering Air Temperature										
Entering Water Temperature										
CFM	GPM	110°F	120°F	130°F	140°F	150°F	160°F	170°F	180°F	Water PD feet WC @140°F
300	3	12080	15070	18110	21160	24200	27260	30310	33370	2.32
	4	12330	15380	18470	21570	24680	27780	30880	33990	3.87
	5	12470	15550	18680	21810	24940	28070	31210	34340	5.77
400	3	15280	19060	22930	26790	30670	34550	38440	42330	2.32
	4	15780	19680	23650	27630	31610	35600	39600	43590	3.87
	5	16070	20030	24070	28110	32150	36210	40260	44310	5.77
600	3	20390	25590	30810	36050	41300	46570	51840	57130	2.32
	4	21530	27000	32490	37990	43500	49020	54550	60090	3.87
	5	22220	27860	33500	39160	44820	50500	56180	61870	5.77
700	3	22490	28260	34040	39840	45660	51500	57340	63200	2.32
	4	23990	30110	36250	42400	48570	54750	60940	67150	3.87
	5	24930	31270	37620	43980	50360	56760	63160	69570	5.77
800	3	24340	30810	37130	43470	49840	56230	62640	69050	2.32
	4	26210	33160	39920	46720	53540	60370	67220	74070	3.87
	5	27400	34640	41690	48760	55860	62960	70080	77210	5.77

90LVS

Performance Data - Hot Water Capacities (BTUH) @ 70°F Entering Air Temperature										
Entering Water Temperature										
CFM	GPM	110°F	120°F	130°F	140°F	150°F	160°F	170°F	180°F	Water PD feet WC @140°F
400	3	15840	19830	23830	27840	31860	35870	39900	43920	1.96
	4	16280	20260	24350	28440	32540	36640	40750	44860	3.26
	5	16520	20590	24730	28880	33040	37190	41360	45520	4.84
600	3	21790	27320	32860	38410	43980	49560	55140	60720	1.96
	4	22880	28130	33840	39570	45310	51060	56820	62590	3.26
	5	23520	28990	34860	40740	46630	52530	58440	64360	4.84
800	3	26370	33080	39830	46590	53370	60170	66980	73790	1.96
	4	28270	34570	41620	48710	55810	62930	70070	77220	3.26
	5	29440	36100	43450	50820	58200	65600	73020	80440	4.84
1,000	3	29960	37370	45010	52680	60380	68090	75820	83560	1.96
	4	32730	40810	49130	57470	65840	74220	82610	91020	3.26
	5	34500	42990	51730	60490	69270	78060	86870	95690	4.84
1,200	3	32810	40920	49310	57740	66190	74670	83170	91670	1.96
	4	36440	45430	54710	64030	73380	82750	92130	101530	3.26
	5	38830	48380	58240	68130	78040	87980	97940	107900	4.84

CIFICATIONS

PHYSICAL DATA - INCHES											
Model	Overall Dimensions W x D x H			Supply Opening W x D		Side Return				Piping Location	
	A	B	C	D	E	F	G	H	I	J	K
50LVS	14.0	21.0	29.0	11.8	17.8	18.3	14.3	1.4	2.0	2.8	2.4
90LVS	21.0	21.0	29.0	18.8	17.8	18.3	14.3	1.4	2.0	2.8	2.4

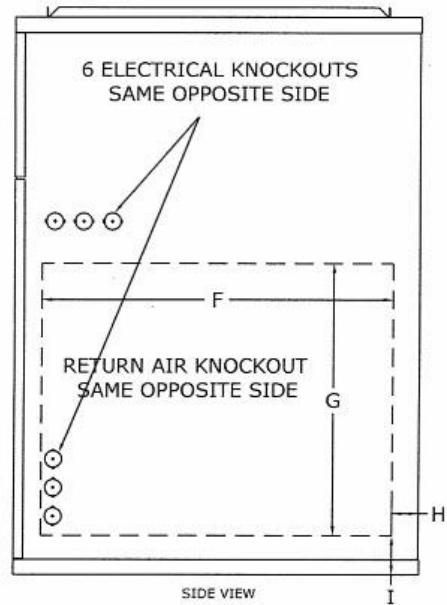
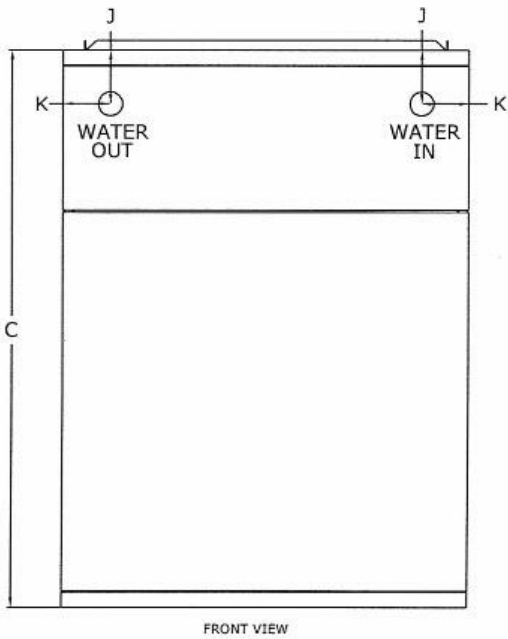
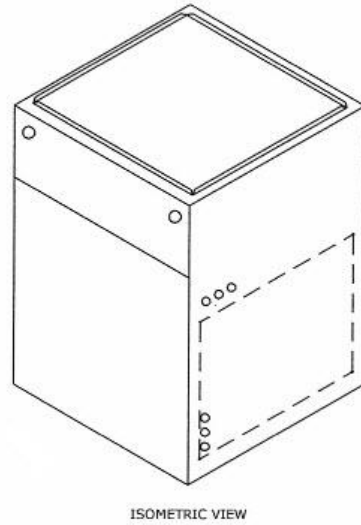
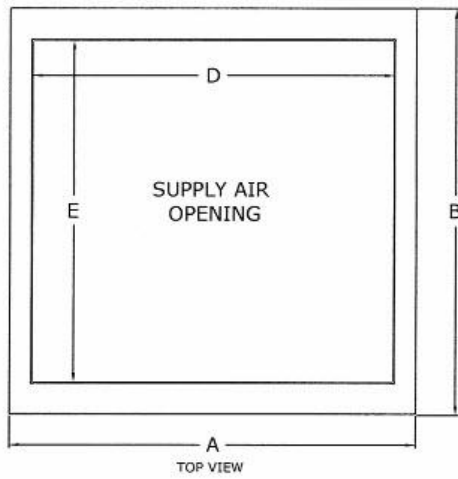

MODEL	50LVS	90LVS
DX Cooling Capacity (tons)	1 to 2	1.5 to 3.5
Power (Volts/Phase/Hz)	120/1/60	120/1/60
Cabinet Size W x D x H (in)	14 x 21 x 29	21 x 21 x 29
Supply Air Opening W x D (in)	11.8 X 17.8	18.8 x 17.8
Side Return Air Opening (in)	18.3 X 14.3	18.3 X 14.3
Recommended Filter Size (in)	16 x 20	16 x 20
Shipping Weight (lb)	85	95
Shipping Dimensions W x D x H (in)	15 x 24 x 30.5	22 x 24 x 30.5

50LVS ECM blower performance (CFM/amps)

SWITCH SETTING *	0.1" WC	0.2" WC	0.3" WC	0.4" WC	0.5" WC	0.6" WC	0.7" WC	0.8" WC	0.9" WC
300CFM	465 0.91	434 0.97	407 1.02	373 1.10	333 1.17	295 1.22	253 1.28	227 1.35	<200 1.41
400CFM	530 1.19	507 1.25	484 1.31	452 1.38	427 1.44	402 1.55	374 1.61	345 1.65	306 1.73
600CFM	701 2.1	690 2.14	673 2.22	655 2.31	632 2.38	615 2.44	597 2.53	573 2.64	555 2.70
700CFM	786 2.73	777 2.76	768 2.85	742 2.93	727 3.01	710 3.11	694 3.19	673 3.28	666 3.25
800CFM	869 3.49	863 3.52	856 3.59	835 3.67	830 3.77	811 3.85	795 3.93	778 4.05	741 3.98

90LVS ECM blower performance (CFM/amps)

SWITCH SETTING *	0.1" WC	0.2" WC	0.3" WC	0.4" WC	0.5" WC	0.6" WC	0.7" WC	0.8" WC	0.9" WC
400CFM	646 1.11	594 1.19	543 1.26	497 1.35	455 1.41	398 1.49	350 1.56	309 1.62	265 1.68
600CFM	804 1.61	763 1.70	725 1.79	680 1.88	639 1.98	604 2.04	571 2.13	534 2.20	490 2.31
800CFM	969 2.40	940 2.50	910 2.64	875 2.73	842 2.83	808 2.93	775 3.02	740 3.11	709 3.22
1000CFM	1136 3.50	1112 3.62	1080 3.73	1059 3.85	1025 3.97	993 4.08	976 4.17	942 4.29	912 4.40
1200CFM	1310 5.00	1283 5.11	1264 5.26	1236 5.40	1214 5.52	1186 5.65	1162 5.79	1108 5.64	1011 5.14

* CFM @ 0.5" WC

QUICK START-UP PROCEDURES

Refer to the installation instructions before following the start-up procedures.

1. Fill the system with water. Do not start the system.
2. Purge all air from the system. Isolation and purge valves are strongly recommended.
3. Purge all air from the space heating loop by closing the isolation valve on the return leg of the loop and open the drain to purge air. Open the return leg isolation valve and then close the drain valve.
4. Start the hot water generating equipment per the manufacturer's recommendations. Set the design water temperature to deliver the necessary amount of BTUs to the air handler.
5. Once all air has been purged, turn on the power to the **ecosmart** and set the room thermostat to heat and set the temperature high enough to initiate a call for heat. This will energize the air handler and in turn the fan and pump.
6. Once the heat source is supplying hot water, check supply and return pipes for a temperature difference to make sure there is flow. There should be a noticeable difference in temperature between supply and return lines. Use caution when supply water temperature is above 120°F / 49°C.

INSTALLATION

The installer must comply with all local and national code requirements pertaining to the installation of this equipment.

Clearances

The **ecosmart** is approved for up-flow, down-flow, and horizontal configurations. Clearances do not change with orientation. This hydronic furnace is for indoor installation only.

	Clearance from Combustibles (in)	Recommended Service Clearance (in)
Top	0	0
Bottom	0	0
Front	0	24
Back	0	0
Sides	0	0

Freeze Protection

It is not recommended to install the **ecosmart** in an unheated space.

Should the **ecosmart** be installed in an area where the ambient temperature may fall below freezing, ethylene or propylene glycol should be added into the hydronic heating system to protect against damage, which would not be covered under warranty. Make sure the glycol is compatible with all system components and is permitted by local and national codes.

Rear Piping Connections

The heating coil may be reversed to allow rear piping:

- Remove upper door
- Disconnect supply air sensor from extension cable
- Slide out heating coil
- Re-mount supply air sensor and grommet to opposite end of heating coil
- Remove rear knockouts
- Slide in heating coil
- Use plastic plugs (provided) to close up holes on upper door

Ecosmart Mounting

The **ecosmart** can be installed in upflow, downflow and left or right horizontal applications.

Install the **ecosmart** with the door in place to make sure the cabinet remains square. Flip the unit for down flow applications so that the top of the unit is now the bottom. No modification is required for any configuration.

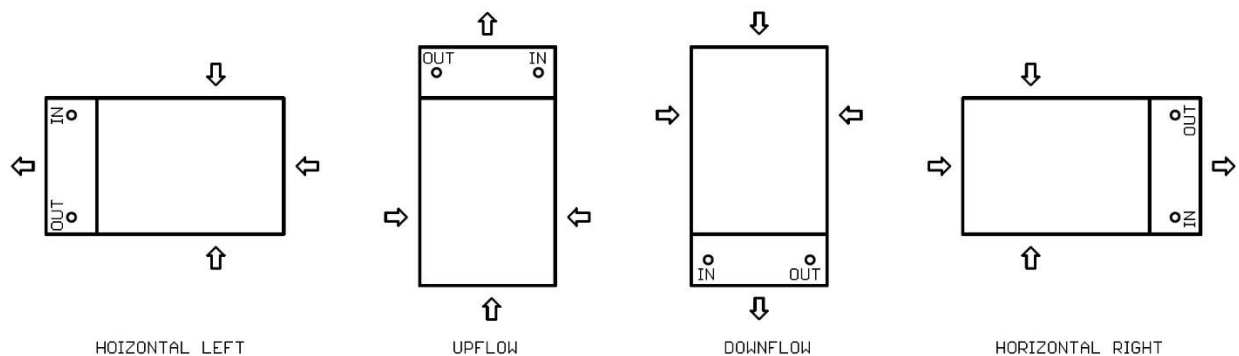

MULTIPOSITION INSTALLATION

The **ecosmart** can be suspended from floor joists, rafters or concrete using rods, pipe, angle supports or straps. Units must be hung level to ensure quiet operation. Vibration isolation is strongly recommended.



CAUTION - Use any of the existing screw holes in the cabinet when using straps. If the existing screw is too short for securing a mounting strap, a longer screw should be used provided care is taken not to damage any internal components. Product warranty does not cover any damage or claims resulting from damage from longer screws or from the unit being improperly suspended.

The cabinet is designed so that the return air can be located on either side of the cabinet, or from the bottom of the cabinet. Position a filter rack so that the filter is readily accessible. A filter and filter rack are not included. Sides have pre-cut knockouts for a standard 16 x 20 in filter rack.



WARNING - Special care should be taken in the vicinity of the coil to avoid puncture. Screw into opening flange instead of top of cabinet when fastening the supply air duct.

Plumbing

Install a sediment faucet or ball valve for use as a drain/purge valve. The drain valve must be located downstream of the pump and check valve, and upstream of the isolation valve (if isolation valve is present). With this arrangement, any air trapped in the system can easily be flushed out following the instructions in the Start-up & Troubleshooting sections. Isolation valves are recommended, but not required. Installing isolation valves facilitates easy servicing.

When the space heating loop connections are made to the domestic water connections:

- The heating loop connections should be positioned horizontally in a vertical section of the domestic water line for both inlet and outlet. Refer to the piping schematic for details.
- Connect the heating loop to the domestic water connections as close to the water heater as possible

Avoid sections of pipe in the heating loop that can trap air where possible. It is usually impossible to install a system without having at least one part of the system or heating coil able to trap air. This will not be a problem if the connection to the domestic water lines is made properly, and purge valves and air eliminator devices are installed.

- Following the flushing procedures in the start-up section will ensure that there is no air in the system after initial set-up.

Follow recommendations supplied by the manufacturer of the heating source being used.

ecosmart includes a flow switch connection where a flow switch can be connected to allow for domestic water priority. Note: the correct type of flow switch is a normally open (NO) device. The flow switch contacts close when domestic water is flowing.

Check Valve

A check valve may be required for your system to meet local codes and to work effectively. A check valve:

- Protects against back-flow of water to avoid short circuiting around the water heater during domestic use
- Protects against thermal siphoning
- Is required in all potable water systems

Drain Pan

A drain pan is recommended underneath the appliance for all installations in case of heat exchanger failure.

Pump

A pump is not included inside the **ecosmart**. Whether you are using an external pump or an internal built-in pump, it should be sized for the system. Pumps supplied with the heat generating units can be used as the sole pump provided it meets the needs of the system. This is especially the case in retrofit applications where a much larger pump may have previously been used in the system.

- When set up in multi-stage mode, the pump will operate as a 3-speed pump if it is a variable 0-10V type. If the pump is a standard 120VAC type, it will operate at a single speed only.
- When set up in single-stage mode, the pump will operate as a single-speed pump.
- The **ecosmart** controller has a built-in pump timer that exercises the pump for 1 minute every 24 hours to prevent the possibility of 'sticking' due to sediment etc.

Water Heater or Boiler Setup

Follow the manufacturer's installation and start-up instructions of the water heater or boiler. Make sure the equipment is turned off during installation and service. Make certain the equipment has been refilled and all air is purged from the system before turning on the heater.



WARNING - When the system requires water temperatures higher than 120°F, a mixing valve shall be installed to reduce domestic hot water temperature to safeguard against scalding.

Combo Systems

The **ecosmart** is ideal for use in combo systems which provide space heating and domestic hot water from a single heat source. Any properly sized gas, propane or oil-fired water heater or boiler will work in a combo system. Make sure any water heater being used is approved for combo applications.

PIPING DIAGRAMS

Tankless Water Heater Piping

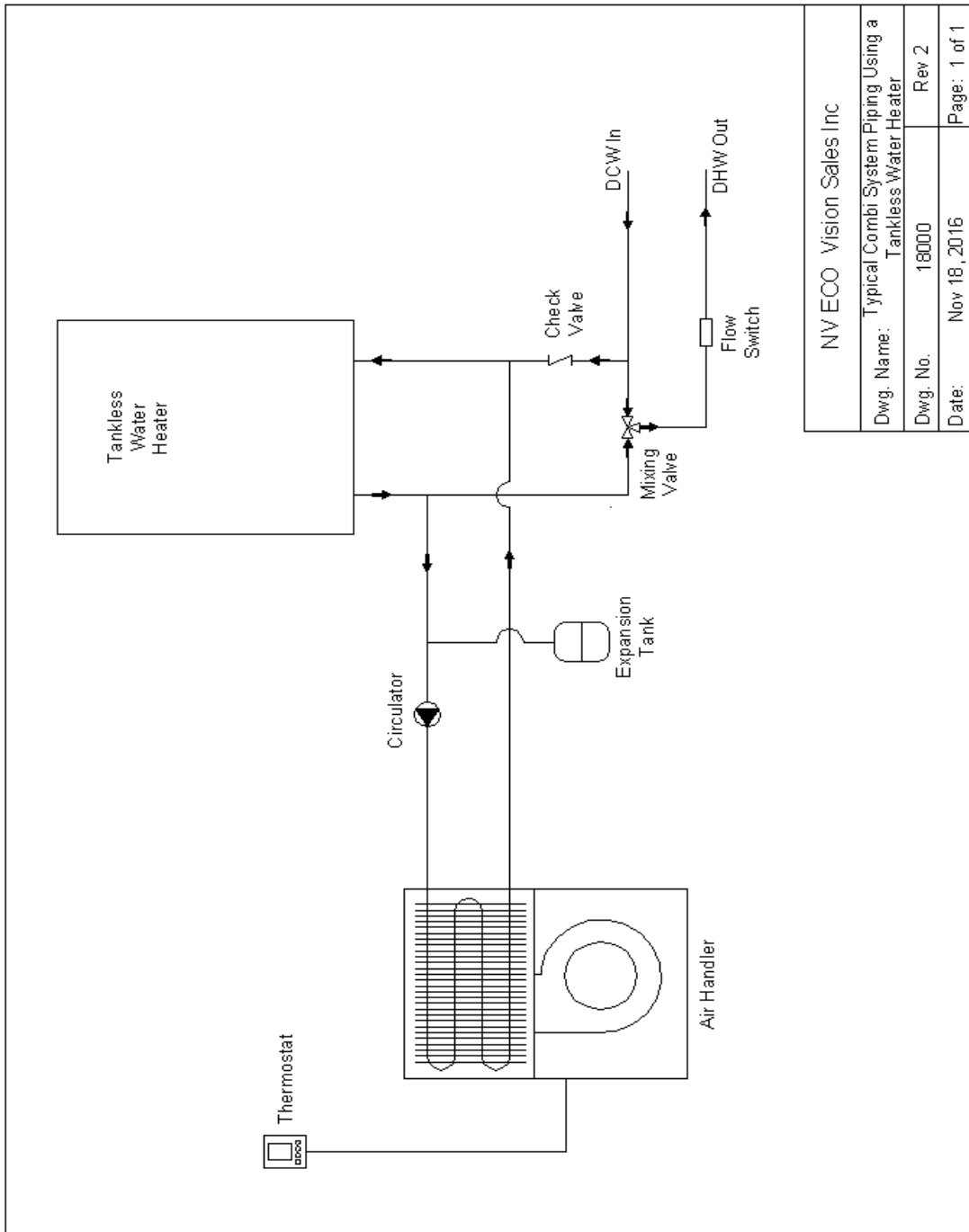

NV ECO Vision Sales Inc	
Dwg. Name:	Typical Combi System Piping Using a Tankless Water Heater
Dwg. No.	18000 Rev 2
Date:	Nov 18, 2016 Page: 1 of 1

Combi-Boiler Piping

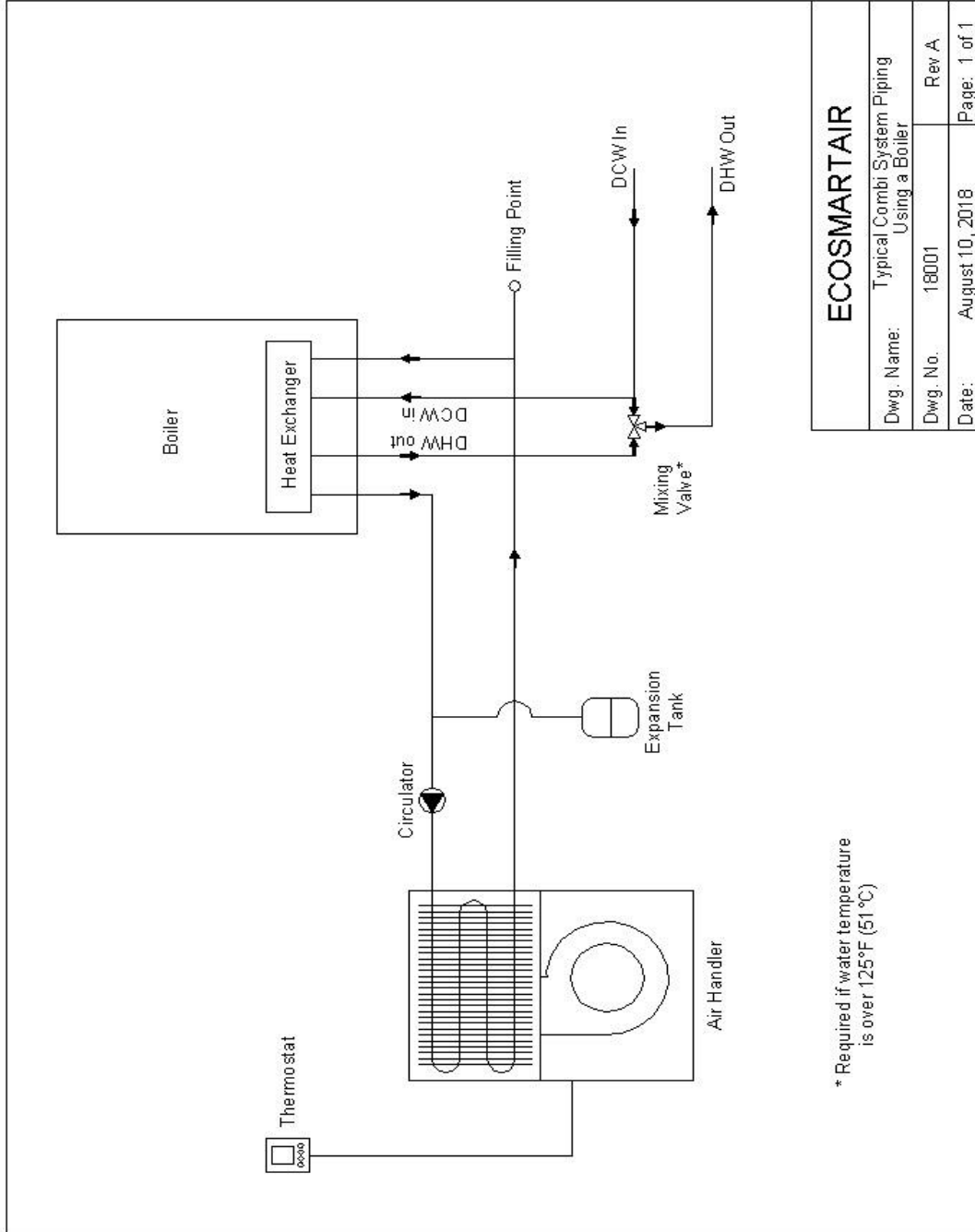

ECOSMARTAIR

Dwg. Name:	Typical Combi System Piping Using a Boiler	Rev. A
Dwg. No.	18001	Page: 1 of 1
Date:	August 10, 2018	

* Required if water temperature is over 125°F (51°C)

ELECTRICAL



WARNING - Make sure the installation meets all national and local electrical codes.

Electrical Information

The ecosmart wiring diagram is located on the cover of the electrical box behind the lower front panel. Ratings data is located on the lower front panel.

- The ecosmart operates on 120VAC 60Hz single phase line voltage and should have its own dedicated breaker or fuse rated as per the MOP on the ratings label
- All control circuits are standard 24VAC
- **ecosmart** must be grounded via the green wire within the control box

Electrical Connections Made to Quick Connects

- Stranded or solid wire may be used
- Male tab size on control board: 0.250 in x 0.032 in
- Correct female disconnects to mate with male tabs:
 - Wire range: 22-18 AWG (Red) Panduit # DNF18-250 or equivalent
 - Wire range: 16-14 AWG (Blue) Panduit # DNF14-250 or equivalent



Use a quality ratchet crimping tool to ensure reliable connections



LVS Main Wiring

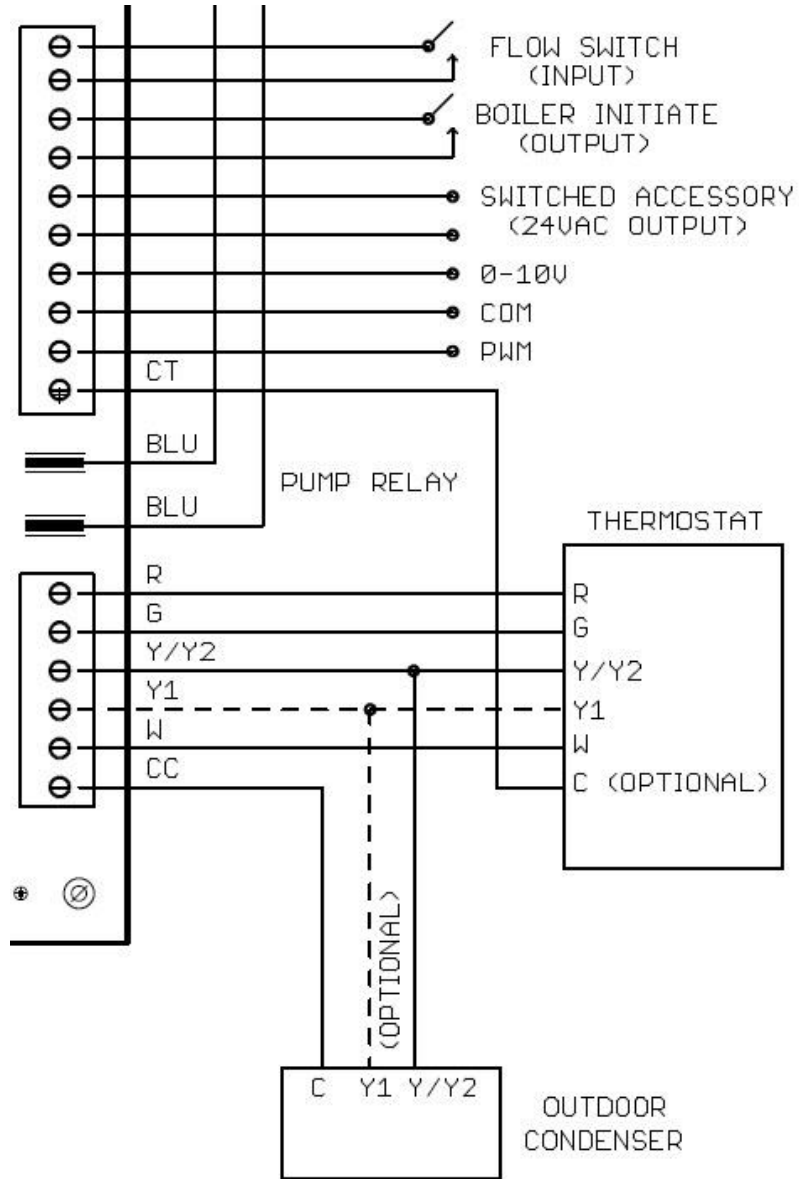

LVS Main Wiring Information

FLOW	When using a water heater and domestic hot water (DHW) priority is required, connect a normally open (NO) flow switch. If there is a call for DHW, fan and pump will shut down after 1 minute. If flow switch is active longer than 30 minutes, fan and pump will resume normal operation.
BOILER	Dry contact to initiate heat source. Active when heating is on.
AUX24V	24VAC output for humidifier or other accessory. Active when heating is on.
0-10V or PWM	Variable speed pump (if installed) will run at LO, MED or HI speeds in the multi-stage mode. Connect between COM and 0-10V for variable voltage output. Connect between COM and PWM for PWM output. (active when heating)
CT	'Always On' C to supply power to 'Smart' thermostats
PUMP RELAY	24VAC power to activate relay for 120VAC pump (active when heating)
R	Thermostat R connection
G	Thermostat G connection
Y/Y2	Thermostat Y or Y2 connection
Y1	Thermostat Y1 connection
W	Thermostat W connection
CC	'Interrupted' C for condenser contactor (on when cooling and air out temperature sensor is above 40°F)

LVS Wiring Diagram

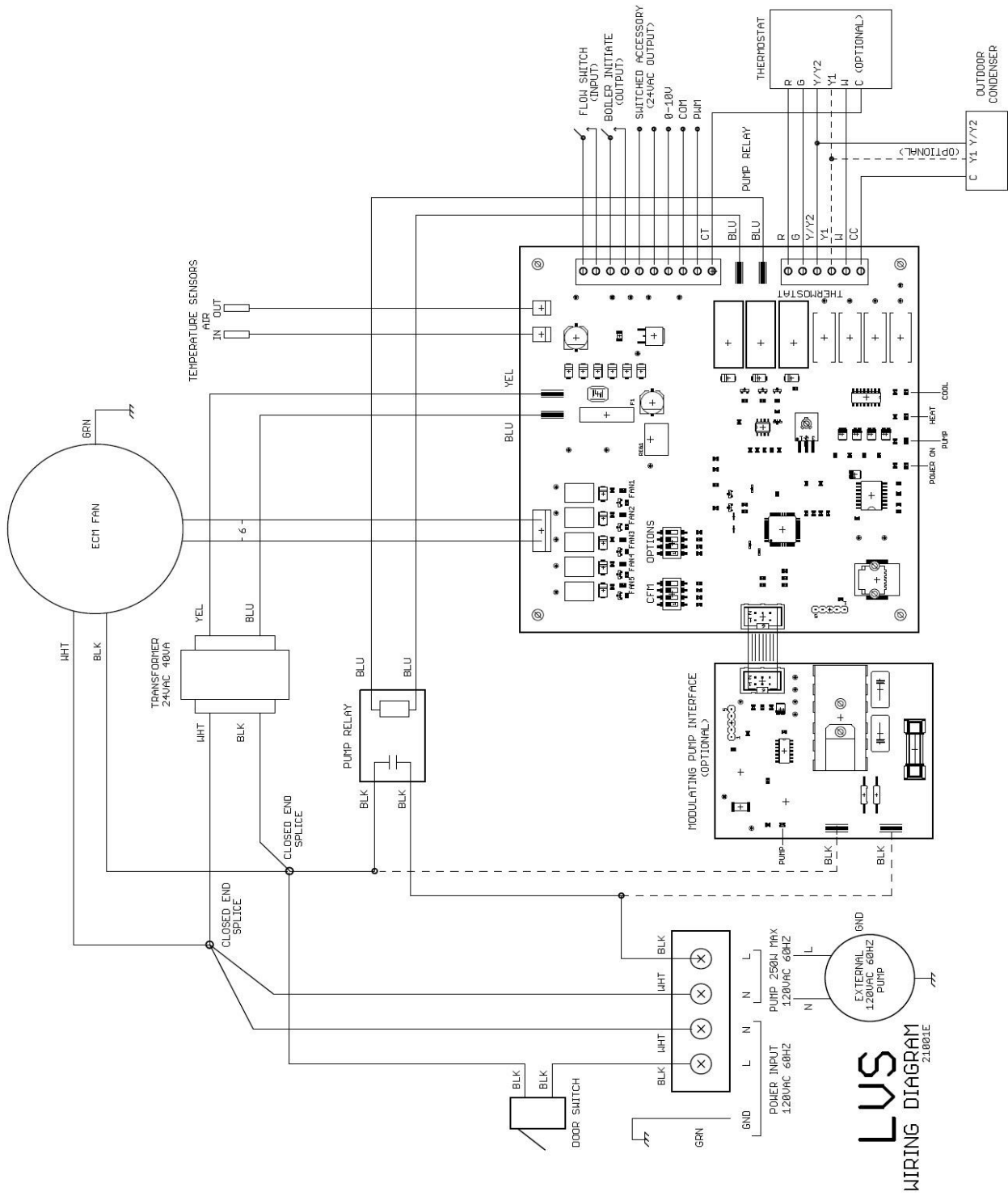

LVS
WIRING DIAGRAM
211801E

LVS Miscellaneous Wiring

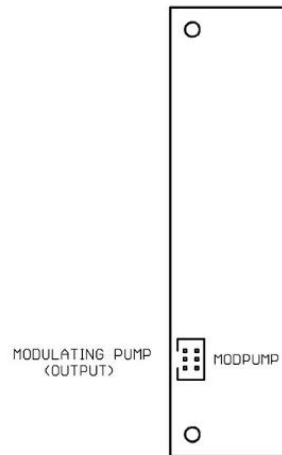

Modulating Pump (Output)	Connects to optional pump drive module P/N 15018. Replaces standard pump relay and allows variable control of a standard 120VAC pump up to 250W.
-----------------------------	---

LVS Indicator Lights

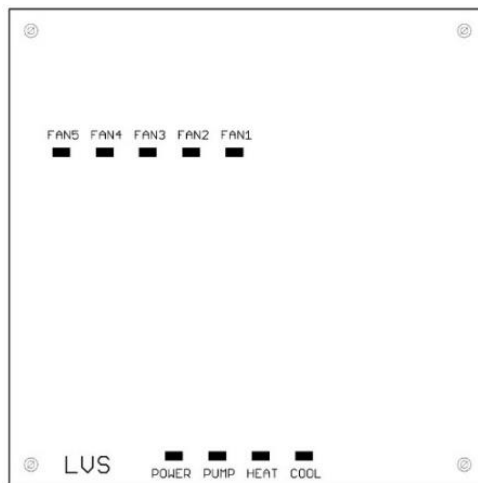

FAN1	Low circulating fan speed
FAN2	Lowest fan speed
FAN3	Low/mid fan speed
FAN4	High/mid fan speed
FAN5	Highest fan speed
POWER	Lights when 24VAC power is present
PUMP	Lights when pump is on
HEAT	Lights when heating
COOL	Lights when cooling

DIP SWITCH OPTIONS

Switch Locations

Two DIP switches labelled CFM and OPTIONS are located on the top left section of the control board. One switch is for Heat and Cool CFM rates, and the other for system options.

WARNING – to prevent damage, use a small screwdriver to change switch position.

Up is ON as marked on the switch body and each switch is identified with numbers below.

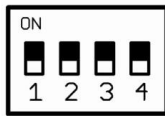

- **CFM** – switches 1 and 2 set Heat CFM rate
- **CFM** – switches 3 and 4 set Cool CFM rate
- **OPTIONS** – sets various system parameters

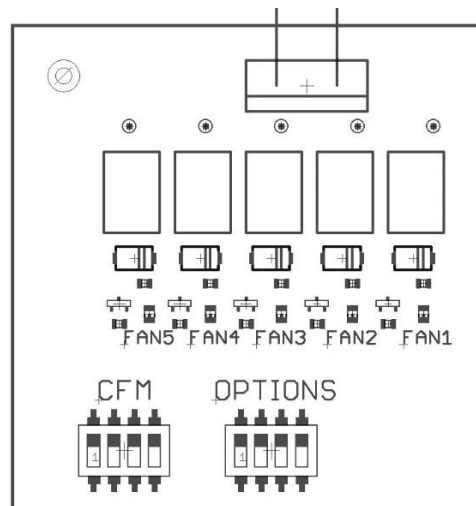

Heat CFM (50LVS)

MULTI-STAGE CFM @ 0.5" WC	SINGLE-STAGE CFM @ 0.5" WC	SWITCH 1	SWITCH 2	VAR. PUMP	STD. PUMP
300/300/400 (1)	400	OFF	OFF	LO/MED/HI (1)	HI
300/400/600 (1)	600	ON	OFF	LO/MED/HI (1)	HI
400/600/700 (1)	700	OFF	ON	LO/MED/HI (1)	HI
600/700/800 (1)	800	ON	ON	LO/MED/HI (1)	HI

(1) Multi-stage sequences are every 5 minutes until last speed is reached.

Heat CFM (90LVS)

MULTI-STAGE CFM @ 0.5" WC	SINGLE-STAGE CFM @ 0.5" WC	SWITCH 1	SWITCH 2	VAR. PUMP	STD. PUMP
400/400/600 (1)	600	OFF	OFF	LO/MED/HI (1)	HI
400/600/800 (1)	800	ON	OFF	LO/MED/HI (1)	HI
600/800/1000 (1)	1000	OFF	ON	LO/MED/HI (1)	HI
800/1000/1200 (1)	1200	ON	ON	LO/MED/HI (1)	HI

(1) Multi-stage sequences are every 5 minutes until last speed is reached.

Cool CFM (50LVS)

CFM @ 0.5" WC	SWITCH 3	SWITCH 4
400/400 (3)	OFF	OFF
400/600 (3)	ON	OFF
600/700 (3)	OFF	ON
700/800 (3)	ON	ON

Cool CFM (90LVS)

CFM @ 0.5" WC	SWITCH 3	SWITCH 4
600/600 (3)	OFF	OFF
600/800 (3)	ON	OFF
800/1000 (3)	OFF	ON
1000/1200 (3)	ON	ON

Options (50LVS and 90LVS)

Mode	SWITCH 1	SWITCH 2	SWITCH 3	SWITCH 4
Constant circulating fan - runs at Heat CFM rate	OFF	X	X	X
Constant low circulating fan (2)	ON	X	X	X
Multi-stage	X	OFF	X	X
Single-stage	X	ON	X	X
Normal Fan Cooling - runs at higher Cool CFM rate	X	X	OFF	X
Dehumidification Fan Cooling (3)	X	X	ON	X
Test Mode off (4)	X	X	X	OFF
Test Mode on (4)	X	X	X	ON

(2) 90LVS runs at 400 CFM, 50LVS runs at 300 CFM.

(3) Fan Cooling runs at **lower** COOL CFM rate for 10 min. and then goes to **higher** rate.

(4) Test Mode – heat source is brought on, fan runs at Single Stage HEAT CFM setting and pump runs at full speed irrespective of thermostat setting. Useful for eliminating air in the system during installation.

SEQUENCE OF OPERATION

Multi-stage Operation

Thermostat calls for heat

- R is connected to W
- Heat generator is turned on
- Auxiliary 24VAC power is turned on
- Pump turns on 100%
- After a 15 second delay to allow for system water to heat up coil, fan ramps up as follows:
 1. **Stage 1 - Lower HEAT CFM fan speed for 5 minutes**
If a variable speed pump is installed, it runs at LO. If a standard single speed AC pump is installed it runs at HI.
 2. **Stage 2 - Medium HEAT CFM fan speed for 5 minutes**
If a variable speed pump is installed, it runs at MED. If a standard single speed AC pump is installed it runs at HI.
 3. **Stage 3 - High HEAT CFM fan speed until thermostat is satisfied**
If a variable speed pump is installed, it runs at HI. If a standard single speed AC pump is installed it runs at HI.

Thermostat is satisfied

- R is disconnected from W
- Heat generator is turned off
- Auxiliary 24VAC power is turned off
- Pump turns off and fan speed ramps down to zero, extracting any remaining heat in the coil

Single-stage Operation

Thermostat calls for heat

- R is connected to W
- Heat generator is turned on
- Auxiliary 24VAC power is turned on
- Pump turns on at 100%
- After a 15 second delay to allow for system water to heat up coil, fan ramps up to HEAT CFM speed
- If a variable speed pump is installed, it runs at HI. If a standard single speed AC pump is installed it runs at HI

Thermostat is satisfied

- R is disconnected from W
- Heat generator is turned off
- Auxiliary 24VAC power is turned off
- Pump turns off and fan speed ramps down to zero, extracting any remaining heat in the coil

Cooling Mode (Multi-stage and Single stage)

(Assumes a condenser and DX coil is installed within the system)

- R is connected to Y/Y2 and Y1*
- Condenser turns on
- Fan ramps up to COOL CFM setting

* If thermostat and condenser support 2-stage cooling

Thermostat is satisfied

- Condenser turns off
- Fan speed ramps down to zero, extracting any remaining cooling from the DX coil

Dehumidification

When in cooling mode, a dehumidification function can be set using system switch 3 as follows:

- OFF - Normal cooling fan runs at rate set by COOL CFM switch
- ON - Fan Cooling runs at lower COOL CFM rate for 10 min. and then goes to higher rate

Fan Mode

- R is connected to G
- If fan is set to “ON” on thermostat, fan runs as follows:
 - If OPTION switch 1 is OFF, fan runs at selected HEAT CFM rate
 - If OPTION switch 1 is ON, fan runs at 300 CFM (ES50LVS), 400CFM (ES90LVS)
- If fan is set to “OFF” on thermostat, fan runs at HEAT or COOL CFM settings

Constant Low Fan Circulation

Fan may be run at a low rate using OPTION switch 1 as follows:

- OFF – fan runs at rate set by HEAT CFM switch
- ES50LVS runs at 300 CFM, ES90LVS runs at 400 CFM

Condenser Lockout/Freeze Protection

The **ecosmart** is equipped with a condenser lockout / freeze protection sensor to help prevent any damage to the hot water coil from a freeze up. In any mode, heating, cooling or standby, when the outlet air temperature sensor reads a temperature of 40°F or lower the **ecosmart** will bring on the circulating fan and energize the pump relay. If in cooling mode, the **ecosmart** will also turn off the condenser by breaking the C connection.

Pump Exerciser

- The circulating pump is exercised for 1 min every 24 hr when the **ecosmart** is OFF, COOLING (Y1), COOLING2 (Y/Y2) or FAN (G) to prevent the possibility of ‘sticking’ due to sediment and to meet local codes
- During the 1 min pump on-time, the fan is turned off and resumes once the pump exercising is completed
- Pump runs continuously if the outlet air temperature drops below 40°F to prevent the chance of freezing

SERVICE AND MAINTENANCE

NOTE: The **ecosmart** is not to be used for temporary heat during construction. Use for this purpose will void equipment warranty.

Filter

Inspect the filter monthly and replace, remove and vacuum or rinse as required. A clogged or inadequate filter may void product warranty.

Coils

Air conditioning and heating coils should not require cleaning if the filter maintenance schedule is adhered to. If a filter is damaged or collapses from plugging, dust may foul the coils. If this happens, replace the filter and carefully vacuum the coils. The coils may need to be removed to gain access to the face of the heating and cooling coil.

Fan and Motor

Check fan for dust once a year. If dirty, vacuum or wash to remove dust. Keeping the fan blades clean will reduce noise and improve capacity and efficiency of the heating system.

TROUBLESHOOTING

Thermostat call error

If the **ecosmart** does not run when the thermostat is calling, jumper R to W for heating or R to Y (Y2) to verify if the problem is with the thermostat or **ecosmart** control. Note that some thermostats have a delay (typically five minutes) before they will re-start cooling to prevent compressor damage.

Water heater temperature and pressure relief valve is weeping

A check valve or back-flow preventer may have been installed in the system. Consult water heater manufacturer's instructions. Optionally install an expansion.

Cold water at hot faucet

When the heat source is a water heater, the most probable cause is reverse flow through the heating loop from a stuck check valve - repair or replace valve.

Fan runs for cooling but not for heating

The room thermostat may be connected improperly. Refer to Electrical section or wiring schematic on **ecosmart** for proper installation.

Fan continues to run in cooling mode when thermostat is satisfied

The condenser shuts off but the **ecosmart** fan continues to run. This is often caused by older thermostats that have built-in heat anticipators. When cooling, the heat anticipator, in parallel with the thermostat contacts, allows a small current to flow to the **ecosmart** control board, keeping the fan on. The contactor in the condenser shuts off because it requires more current to stay on. Solution: replace with a modern thermostat which has no heat anticipator.

Fan not running

The fan has 5 speeds – 4 normal running speeds and a separate low speed for the constant fan circulation. Each active speed has an associated indicator light:

- Check for 120VAC on power connector at motor
 - POWER indicator should be on.
- If power is not present, check door switch
- If power is still not present, check continuity of power cable
- Set to single stage – Options DIP switch 2 on
- Jumper R to G on the thermostat wiring
- Set to low circulating fan – Options DIP switch 1 on
 - FAN1 indicator should light.
- Set to speed 1 – CFM DIP switch 1 & 2 off
 - FAN2 indicator should light.
- Set to speed 2 – CFM DIP switch 1 on & 2 off
 - FAN3 indicator should light.
- Set to speed 3 – CFM DIP switch 1 off & 2 on
 - FAN4 indicator should light.
- Set to speed 4 – CFM DIP switch 1 & 2 on
 - FAN5 indicator should light.
- If 1 -10 above check out, then the motor has failed

Smart WiFi thermostat not working properly

Standard digital thermostats usually have internal batteries and do not require external power.

Smart thermostats may require a constant source of external power for proper operation.

For thermostat power, use the 'CT' connection that is available at all times.

For condenser contactor power, use the 'CC' connection which is on when cooling and the air out temperature sensor is above 40°F.

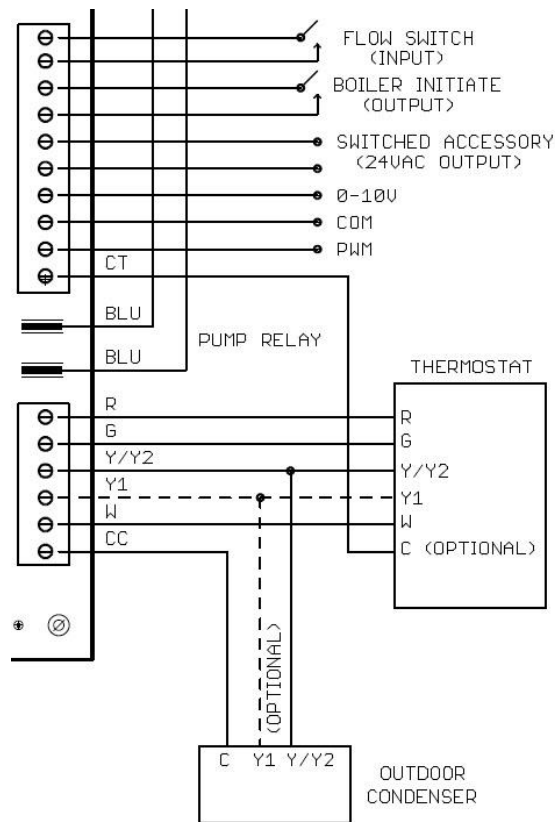

External pump does not run (sticking issue)

In areas where hard water is present the pump may stick and fail to run. Often, closing the isolation valve on the return leg and opening the drain port so that water flows through the pump can free this. If this fails to free the pump, removal for cleaning or replacement is necessary. The daily pump exerciser will help prevent pump sticking.

External pump does not run (electrical issue)

Two types of pumps can be used with the **ecosmart**: standard 120VAC pumps or variable speed pumps with a 0-10V control voltage input.

1. Jumper R to W or set to test mode – Options DIP switch 4 on
2. Relay will click on and 120VAC should appear on power connector
3. 10VDC should also appear on 0-10V output for variable pump operation
4. PUMP indicator should be on

External pump is noisy at start-up

If sound has not diminished within 1 minute, air may be present in the system and may need re-purging. If the heat source is a water heater, check to make sure branch connections for the heating loop are horizontal to prevent the collecting of air in the loop. Install air eliminating device at high point in system.

Insufficient or no heat

- Check that the heat generator is functioning properly
- Plugged air filter or coil. Refer to maintenance section for filter care and coil cleaning
- Air in heating loop - purge system
- Inlet and outlet connections to **ecosmart** are backwards - reverse connections
- Water heater dip tube is restricted or damaged; check and/or replace
- Supply water temperature set too low or not calibrated properly - check water temperature
- Restrictions in heating loop - remove restrictions, check if valve is stuck, isolation valves could be too restrictive or left partially closed after purging, or a closed valve

Heating during standby mode

Probable cause is thermal siphoning.

Pump and fan run continuously

Air out sensor monitors the temperature above the heating coil in the supply airstream and will turn on the pump and fan if temperature goes below 40°F.

- Make sure Air out temperature sensor plug is properly seated into board connector
- Sensor resistance should be approximately 10K at room temperature

REMOVING BLOWER/CONTROL ASSEMBLY

Blower and control assembly can be removed as a single piece:

- Turn off power to **ecosmart**
- Disconnect AIR OUT temperature sensor (white plug/socket) just above front centre plate and pull up out of the way to prevent damage to the cable when sliding out assembly
- Disconnect power, thermostat and other wiring from within control box
- Undo (Qty. 2) #1/4-20 bolts, lock washers and flat washers
- Slide out blower assembly
-

CONTROL ASSEMBLY LAYOUT

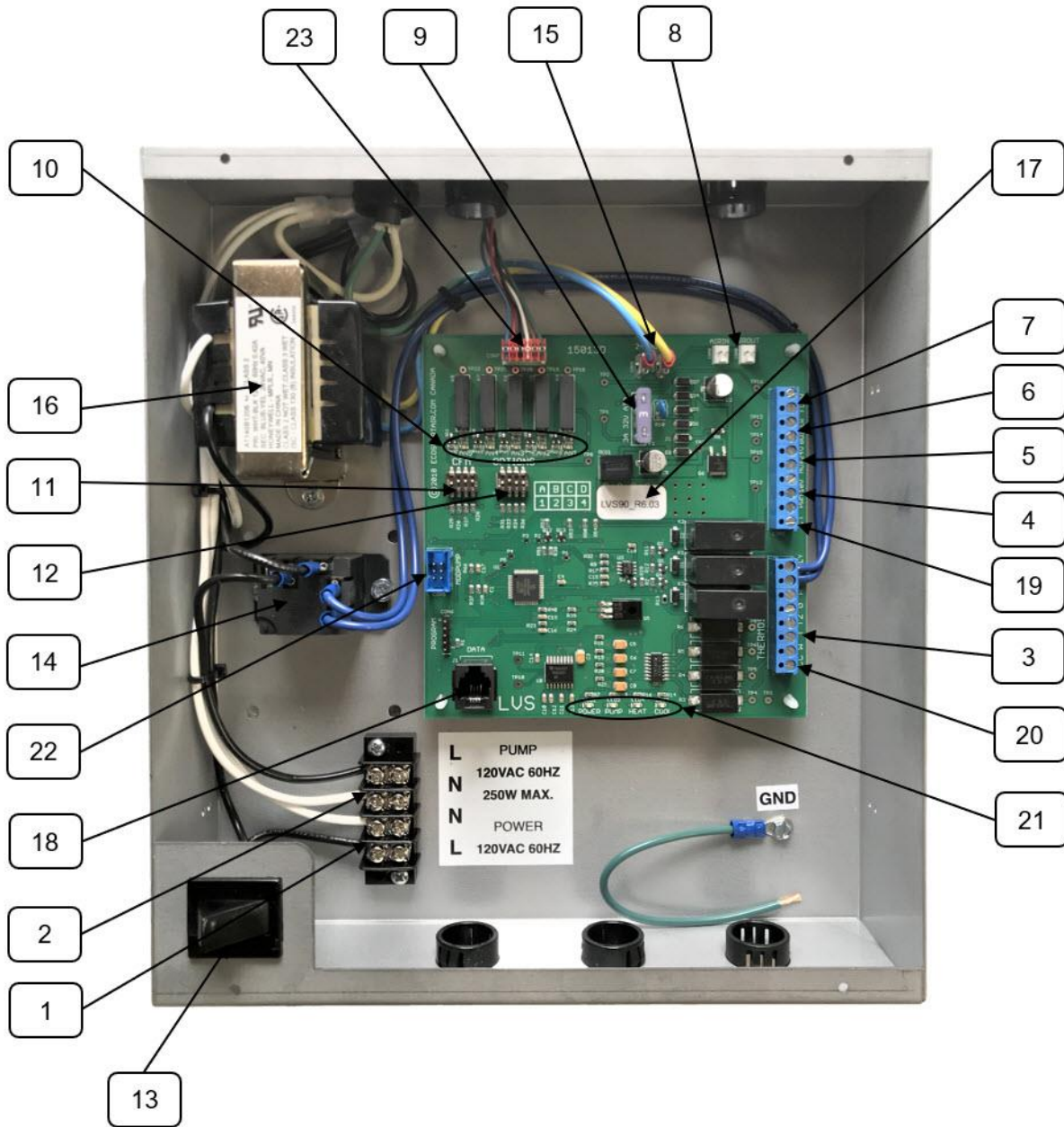

1	120VAC 60Hz single phase power input
2	120VAC 250W Max. pump output from relay
3	Thermostat connection: R, G, Y/Y2, Y1, W
4	PWM and 0-10VDC for variable speed pump (optional)
5	Auxiliary 24VAC accessory output – active when heating
6	Dry contacts to bring on heat source
7	Flow switch input for domestic hot water priority
8	Air in/out temperature sensors
9	Fuse 3A 32V ATO type
10	Fan speed indicators Fan 5, 4, 3, 2, 1 (1=low speed circulating fan setting)
11	Heat/cool CFM DIP switches
12	Options DIP switches
13	Door switch
14	Pump relay
15	24VAC output from transformer: Blue = R, Yellow = C
16	24VAC 40VA transformer
17	Software version identifier
18	Diagnostic connector
19	CT 'C Thermostat' for smart thermostat power (always on)
20	CC 'C Condenser' cuts out when supply air goes below 40°F (disables condenser)
21	Status indicators (power on, pump, heat, cool)
22	Modulating pump interface (optional)
23	Fan control connector

Final Assembly – Exploded View

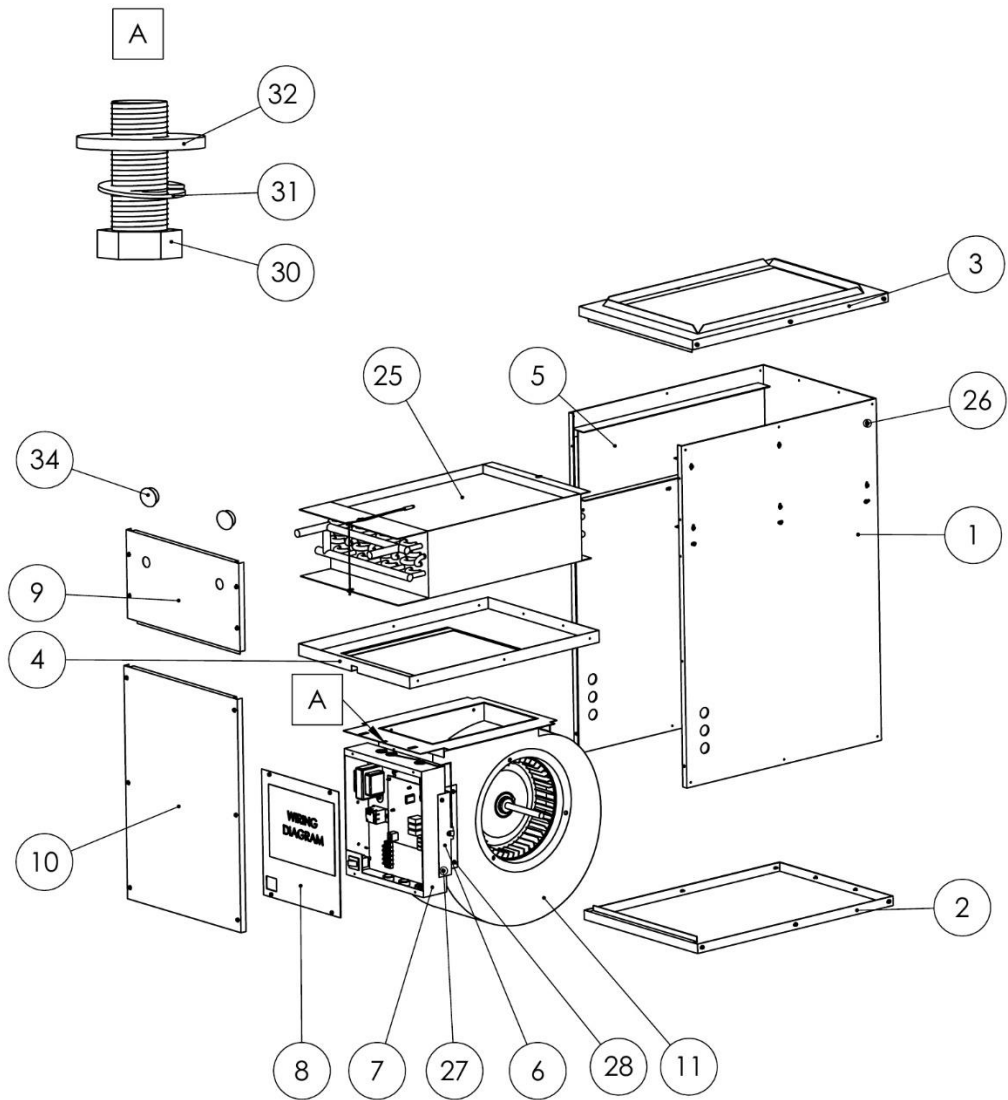

Electrical Box– Exploded View

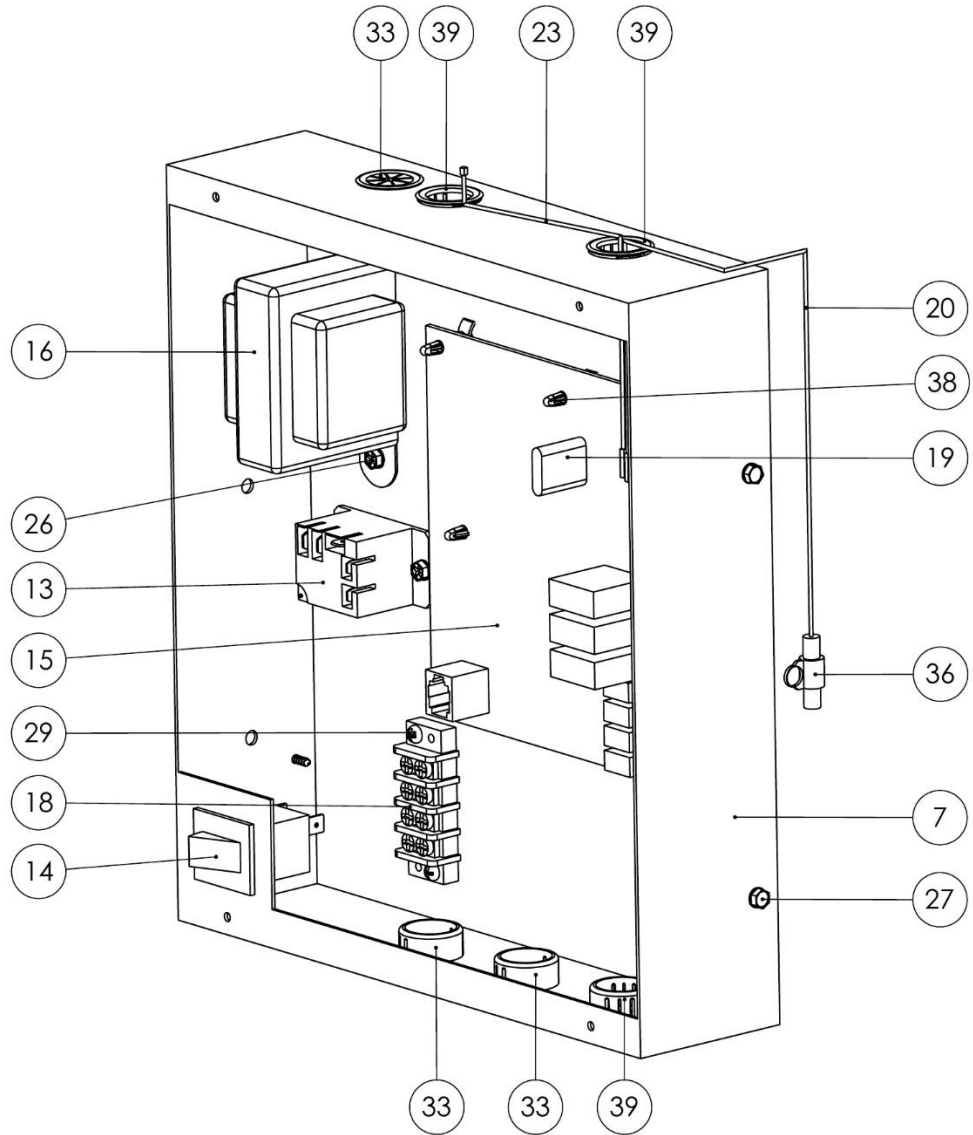

Blower & Heating Coil – Exploded View

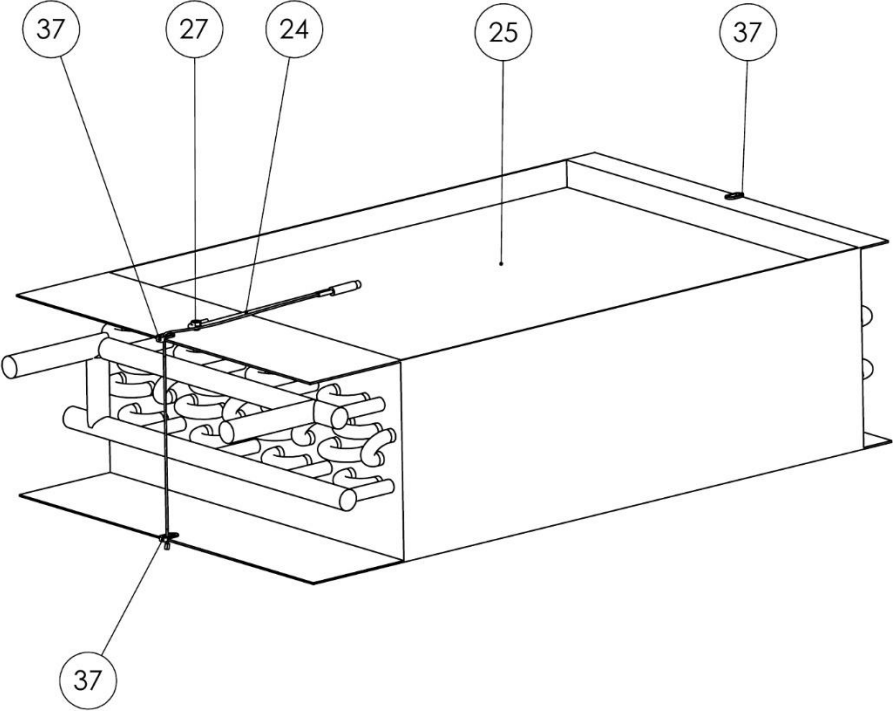
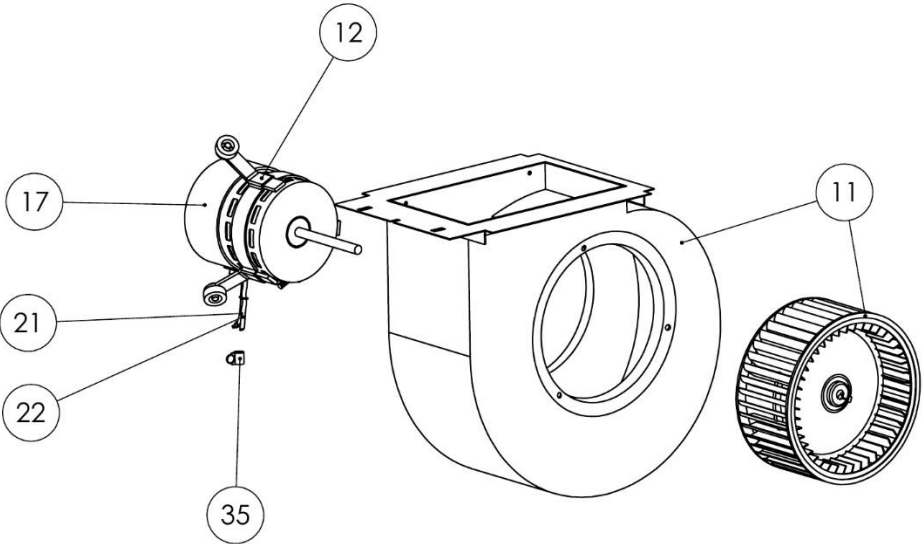

Replacement Parts

Replacement Parts LVS Models					
Item	Part Number	Part Number		Description	Qty.
	50LVS	90LVS			
METALWORK					
1	24041	24042		Wrapper insulated	1
2	24044	24045		Bottom cover insulated	1
3	16015	16002		Top cover	1
4	16016	16003		Centre plate	1
5	16005	16005		Coil rail	2
6	16036	16006		Electrical box support	2
7	16007	16007		Electrical box	1
8	16008	16008		Electrical box cover	1
9	24047	24048		Upper door insulated	1
10	24050	24051		Lower door insulated	1
BLOWER ASSY					
11	16033	16004		Blower assy.	1
12	16035	16035		Motor mount set BB-10-4 (short arm)	1
ELECTRICAL					
13	18010	18010		Relay 24VAC 10A contact SPST	1
14	18000	18000		Door Switch	1
15	1501350	1501390		PCA Ecosmart LVS Controller	1
16	24062	24062		Transformer 120VAC 24VAC 40VA	1
17	18027LVS50	18027LVS90		Motor EC Selectech	1
18	18011	18011		Barrier block 20A 4 pos	1
19	18020	18020		Fuse 3A	2
WIRING					
20	20000	20000		Cable assy. temp sensor 10K	1
21	20003	20003		Cable assy. LVS motor combi	1
23	20008	20008		Cable assy. temp sensor extension	1
24	24032	24032		Cable assy. supply temp sensor	1

Heating Coil					
25	17007	17003		Hydronic Heating coil	1
HARDWARE					
26	19000	19000		Screw Selftap #8 x 3/8in Type AB Hex/PHP Zinc	50
27	19001	19001		Screw Selftap #8 x 3/8in Type B Serrated Hex Zinc	10
28	19018	19018		Screw Selftap #8 x 3/8in Type Selfdrill Hex Zinc	4
29	19011	19011		Screw Selftap #6 x 1/2in Type A PNP Zinc	2
30	19015	19015		Bolt 1/4 x 20 x 3/4in zinc	2
31	19016	19016		Lockwasher 1/4in zinc	2
32	19017	19017		Washer 1/4in zinc	2
33	19012	19012		Bushing universal 0.875 blk	3
34	19007	19008		Dome plug blk	2
35	19013	19013		Cable clip 7/16in blk	1
36	19014	19014		Cable clip 3/16in blk	1
37	19003	19003		Grommet 0.625OD 0.312ID blk	4
38	19004	19004		Control board support	4
39	19026	19026		Bushing snap 0.875 blk	3
MISC					
	14001	14001		Ecosmart LVS Installation, Operations and Maintenance Manual	1
	14004	14004		Ecosmart LVS Brochure	1

WARRANTY

Warranty is 3 years' parts. Visit ecosmartair.com for full details.